

APPENDIX A

TRAFFIC COUNT WORKSHEETS

Existing Volume Development - AM Peak Hour

1: Eisenhower Drive / Calle Sinaloa

PHF:	<u>0.976</u>												
Date:	<u>10/28/2010</u>												
	<u>NBL</u>	<u>NBT</u>	<u>NBR</u>	<u>SBL</u>	<u>SBT</u>	<u>SBR</u>	<u>EBL</u>	<u>EBT</u>	<u>EBR</u>	<u>WBL</u>	<u>WBT</u>	<u>WBR</u>	<u>TOTAL</u>
2010:	8	339	95	21	137	27	78	143	4	98	41	20	1,011
2012:	8	346	97	21	140	28	80	146	4	100	42	20	1,031
Seasonal:	9	398	111	25	161	32	92	168	5	115	48	23	1,186

2: Avenida Navarro / Avenida Montezuma

PHF:	<u>0.808</u>												
Date:	<u>5/25/2010</u>												
	<u>NBL</u>	<u>NBT</u>	<u>NBR</u>	<u>SBL</u>	<u>SBT</u>	<u>SBR</u>	<u>EBL</u>	<u>EBT</u>	<u>EBR</u>	<u>WBL</u>	<u>WBT</u>	<u>WBR</u>	<u>TOTAL</u>
2010:	3	35	18	4	0	0	3	67	2	12	23	1	168
2012:	3	36	18	4	0	0	3	68	2	12	23	1	171
Seasonal:	4	41	21	5	0	0	4	79	2	14	27	1	197

3: Driveway 1 / Avenida Montezuma

PHF:	<u>0.950</u>												
Date:	<u>5/25/2010</u>												
	<u>NBL</u>	<u>NBT</u>	<u>NBR</u>	<u>SBL</u>	<u>SBT</u>	<u>SBR</u>	<u>EBL</u>	<u>EBT</u>	<u>EBR</u>	<u>WBL</u>	<u>WBT</u>	<u>WBR</u>	<u>TOTAL</u>
2012:	3	0	14	0	0	0	0	96	8	13	39	0	174

4: Driveway 2 / Avenida Montezuma

PHF:	<u>0.950</u>												
Date:	<u>5/25/2010</u>												
	<u>NBL</u>	<u>NBT</u>	<u>NBR</u>	<u>SBL</u>	<u>SBT</u>	<u>SBR</u>	<u>EBL</u>	<u>EBT</u>	<u>EBR</u>	<u>WBL</u>	<u>WBT</u>	<u>WBR</u>	<u>TOTAL</u>
2012:	2	0	21	0	0	0	0	105	5	19	50	0	203

5: Avenida Bermudas / Avenida Montezuma

PHF:	<u>0.859</u>												
Date:	<u>5/25/2010</u>												
	<u>NBL</u>	<u>NBT</u>	<u>NBR</u>	<u>SBL</u>	<u>SBT</u>	<u>SBR</u>	<u>EBL</u>	<u>EBT</u>	<u>EBR</u>	<u>WBL</u>	<u>WBT</u>	<u>WBR</u>	<u>TOTAL</u>
2010:	19	88	0	0	72	38	71	0	35	0	0	0	323
2012:	19	90	0	0	73	39	72	0	36	0	0	0	329
Seasonal:	22	107	0	0	84	47	86	0	41	0	0	0	388

6: Avenida Bermudas / Calle Estado (North)

PHF:	<u>0.852</u>												
Date:	<u>5/25/2010</u>												
	<u>NBL</u>	<u>NBT</u>	<u>NBR</u>	<u>SBL</u>	<u>SBT</u>	<u>SBR</u>	<u>EBL</u>	<u>EBT</u>	<u>EBR</u>	<u>WBL</u>	<u>WBT</u>	<u>WBR</u>	<u>TOTAL</u>
2010:	0	102	0	0	106	0	0	0	0	8	0	8	224
2012:	0	104	0	0	108	0	0	0	0	8	0	8	229
Seasonal:	0	120	0	0	125	0	0	0	0	9	0	9	264

7: Avenida Bermudas / Driveway 3

PHF:	<u>0.950</u>												
Date:	<u>5/25/2010</u>												
	<u>NBL</u>	<u>NBT</u>	<u>NBR</u>	<u>SBL</u>	<u>SBT</u>	<u>SBR</u>	<u>EBL</u>	<u>EBT</u>	<u>EBR</u>	<u>WBL</u>	<u>WBT</u>	<u>WBR</u>	<u>TOTAL</u>
2010:	6	102	0	0	114	0	0	0	9	0	0	0	231
2012:	6	104	0	0	116	0	0	0	9	0	0	0	236
Seasonal:	7	120	0	0	134	0	0	0	11	0	0	0	271

Existing Volume Development - AM Peak Hour

8: Avenida Bermudas / Calle Estado (South)

PHF:	0.852												
Date:	5/25/2010												
	<u>NBL</u>	<u>NBT</u>	<u>NBR</u>	<u>SBL</u>	<u>SBT</u>	<u>SBR</u>	<u>EBL</u>	<u>EBT</u>	<u>EBR</u>	<u>WBL</u>	<u>WBT</u>	<u>WBR</u>	<u>TOTAL</u>
2010:	0	108	3	12	111	0	0	0	0	0	0	0	234
2012:	0	110	3	12	113	0	0	0	0	0	0	0	239
Seasonal:	0	127	4	14	131	0	0	0	0	0	0	0	276

9: Avenida Bermudas / Avenue 52/Calle Sinaloa

PHF:	0.959												
Date:	5/25/2010												
	<u>NBL</u>	<u>NBT</u>	<u>NBR</u>	<u>SBL</u>	<u>SBT</u>	<u>SBR</u>	<u>EBL</u>	<u>EBT</u>	<u>EBR</u>	<u>WBL</u>	<u>WBT</u>	<u>WBR</u>	<u>TOTAL</u>
2010:	4	66	790	29	27	12	17	317	3	146	150	20	1,581
2012:	4	67	806	30	28	12	17	323	3	149	153	20	1,613
Seasonal:	5	77	927	34	32	14	20	372	4	171	176	23	1,855

10: Washington Street / Eisenhower Drive

PHF:	0.910												
Date:	5/25/2010												
	<u>NBL</u>	<u>NBT</u>	<u>NBR</u>	<u>SBL</u>	<u>SBT</u>	<u>SBR</u>	<u>EBL</u>	<u>EBT</u>	<u>EBR</u>	<u>WBL</u>	<u>WBT</u>	<u>WBR</u>	<u>TOTAL</u>
2010:	110	839	59	53	833	46	152	123	184	166	123	149	2,837
2012:	112	856	60	54	850	47	155	125	188	169	125	152	2,894
Seasonal:	129	984	69	62	977	54	178	144	216	195	144	175	3,328

11: Washington Street / Calle Tampico

PHF:	0.871												
Date:	5/25/2010												
	<u>NBL</u>	<u>NBT</u>	<u>NBR</u>	<u>SBL</u>	<u>SBT</u>	<u>SBR</u>	<u>EBL</u>	<u>EBT</u>	<u>EBR</u>	<u>WBL</u>	<u>WBT</u>	<u>WBR</u>	<u>TOTAL</u>
2010:	42	629	44	26	353	307	279	52	34	28	72	54	1,920
2012:	43	642	45	27	360	313	285	53	35	29	73	55	1,959
Seasonal:	49	738	52	31	414	360	327	61	40	33	84	63	2,252

12: Washington Street / Avenue 52

PHF:	0.958												
Date:	5/25/2010												
	<u>NBL</u>	<u>NBT</u>	<u>NBR</u>	<u>SBL</u>	<u>SBT</u>	<u>SBR</u>	<u>EBL</u>	<u>EBT</u>	<u>EBR</u>	<u>WBL</u>	<u>WBT</u>	<u>WBR</u>	<u>TOTAL</u>
2010:	2	10	4	170	8	169	729	344	0	22	154	196	1,808
2012:	2	10	4	173	8	172	744	351	0	22	157	200	1,844
Seasonal:	2	12	5	199	9	198	855	404	0	26	181	230	2,121

* In accordance with the City of La Quinta's traffic study guidelines (Engineering Bulletin #06-13, revised September 10, 2010), traffic counts should consider the seasonal population variations within the City. Traffic counts conducted during the off-season period of May shall be increase by 15% and 10% for October. However, the "seasonal" volumes include the increase of 2% to 2010 traffic counts and the application of a 15% seasonal factor.

Existing Volume Development - PM Peak Hour

1: Eisenhower Drive / Calle Sinaloa

PHF:	0.854												
Date:	10/28/2010												
	<u>NBL</u>	<u>NBT</u>	<u>NBR</u>	<u>SBL</u>	<u>SBT</u>	<u>SBR</u>	<u>EBL</u>	<u>EBT</u>	<u>EBR</u>	<u>WBL</u>	<u>WBT</u>	<u>WBR</u>	<u>TOTAL</u>
2010:	9	216	47	34	292	55	27	64	16	231	84	28	1,103
2012:	9	220	48	35	298	56	28	65	16	236	86	29	1,125
Seasonal:	11	253	55	40	343	65	32	75	19	271	99	33	1,294

2: Avenida Navarro / Avenida Montezuma

PHF:	0.803												
Date:	5/25/2010												
	<u>NBL</u>	<u>NBT</u>	<u>NBR</u>	<u>SBL</u>	<u>SBT</u>	<u>SBR</u>	<u>EBL</u>	<u>EBT</u>	<u>EBR</u>	<u>WBL</u>	<u>WBT</u>	<u>WBR</u>	<u>TOTAL</u>
2010:	6	29	42	0	1	3	9	50	7	8	24	4	183
2012:	6	30	43	0	1	3	9	51	7	8	24	4	187
Seasonal:	7	34	49	0	1	4	11	59	8	9	32	5	219

3: Driveway 1 / Avenida Montezuma

PHF:	0.950												
Date:	5/25/2010												
	<u>NBL</u>	<u>NBT</u>	<u>NBR</u>	<u>SBL</u>	<u>SBT</u>	<u>SBR</u>	<u>EBL</u>	<u>EBT</u>	<u>EBR</u>	<u>WBL</u>	<u>WBT</u>	<u>WBR</u>	<u>TOTAL</u>
2012:	8	0	12	0	0	0	0	92	16	14	38	0	180

4: Driveway 2 / Avenida Montezuma

12 PHF:	0.950												
Date:	5/25/2010												
	<u>NBL</u>	<u>NBT</u>	<u>NBR</u>	<u>SBL</u>	<u>SBT</u>	<u>SBR</u>	<u>EBL</u>	<u>EBT</u>	<u>EBR</u>	<u>WBL</u>	<u>WBT</u>	<u>WBR</u>	<u>TOTAL</u>
2012:	5	0	18	0	0	0	0	94	10	21	47	0	195

5: Avenida Bermudas / Avenida Montezuma

PHF:	0.930												
Date:	5/25/2010												
	<u>NBL</u>	<u>NBT</u>	<u>NBR</u>	<u>SBL</u>	<u>SBT</u>	<u>SBR</u>	<u>EBL</u>	<u>EBT</u>	<u>EBR</u>	<u>WBL</u>	<u>WBT</u>	<u>WBR</u>	<u>TOTAL</u>
2010:	13	82	0	0	152	45	70	0	25	0	0	0	387
2012:	13	84	0	0	155	46	71	0	26	0	0	0	395
Seasonal:	15	96	0	0	187	53	82	0	30	0	0	0	464

6: Avenida Bermudas / Calle Estado (North)

PHF:	0.919												
Date:	5/25/2010												
	<u>NBL</u>	<u>NBT</u>	<u>NBR</u>	<u>SBL</u>	<u>SBT</u>	<u>SBR</u>	<u>EBL</u>	<u>EBT</u>	<u>EBR</u>	<u>WBL</u>	<u>WBT</u>	<u>WBR</u>	<u>TOTAL</u>
2010:	0	76	0	0	185	0	0	0	0	12	0	15	288
2012:	0	78	0	0	189	0	0	0	0	12	0	15	294
Seasonal:	0	93	0	0	217	0	0	0	0	14	0	18	342

7: Avenida Bermudas / Driveway 3

PHF:	0.950												
Date:	5/25/2010												
	<u>NBL</u>	<u>NBT</u>	<u>NBR</u>	<u>SBL</u>	<u>SBT</u>	<u>SBR</u>	<u>EBL</u>	<u>EBT</u>	<u>EBR</u>	<u>WBL</u>	<u>WBT</u>	<u>WBR</u>	<u>TOTAL</u>
2010:	9	75	0	0	197	0	1	0	22	0	0	0	304
2012:	9	77	0	0	201	0	1	0	22	0	0	0	310
Seasonal:	11	92	0	0	231	0	1	0	26	0	0	0	361

Existing Volume Development - PM Peak Hour

8: Avenida Bermudas / Calle Estado (South)

PHF:	0.919												
Date:	5/25/2010												
	<u>NBL</u>	<u>NBT</u>	<u>NBR</u>	<u>SBL</u>	<u>SBT</u>	<u>SBR</u>	<u>EBL</u>	<u>EBT</u>	<u>EBR</u>	<u>WBL</u>	<u>WBT</u>	<u>WBR</u>	<u>TOTAL</u>
2010:	0	84	8	11	208	0	0	0	0	0	0	0	311
2012:	0	86	8	11	212	0	0	0	0	0	0	0	317
Seasonal:	0	103	9	13	244	0	0	0	0	0	0	0	369

9: Avenida Bermudas / Avenue 52/Calle Sinaloa

PHF:	0.940												
Date:	5/25/2010												
	<u>NBL</u>	<u>NBT</u>	<u>NBR</u>	<u>SBL</u>	<u>SBT</u>	<u>SBR</u>	<u>EBL</u>	<u>EBT</u>	<u>EBR</u>	<u>WBL</u>	<u>WBT</u>	<u>WBR</u>	<u>TOTAL</u>
2010:	0	42	316	21	86	40	19	170	5	465	355	22	1,541
2012:	0	43	322	21	88	41	19	173	5	474	362	22	1,572
Seasonal:	0	49	371	25	101	47	22	199	6	545	416	26	1,808

10: Washington Street / Eisenhower Drive

PHF:	0.942												
Date:	5/25/2010												
	<u>NBL</u>	<u>NBT</u>	<u>NBR</u>	<u>SBL</u>	<u>SBT</u>	<u>SBR</u>	<u>EBL</u>	<u>EBT</u>	<u>EBR</u>	<u>WBL</u>	<u>WBT</u>	<u>WBR</u>	<u>TOTAL</u>
2010:	202	978	95	19	622	62	98	67	194	85	68	16	2,506
2012:	206	998	97	19	635	63	100	68	198	87	69	16	2,556
Seasonal:	237	1,147	111	22	730	73	115	79	228	100	80	19	2,940

11: Washington Street / Calle Tampico

PHF:	0.902												
Date:	5/25/2010												
	<u>NBL</u>	<u>NBT</u>	<u>NBR</u>	<u>SBL</u>	<u>SBT</u>	<u>SBR</u>	<u>EBL</u>	<u>EBT</u>	<u>EBR</u>	<u>WBL</u>	<u>WBT</u>	<u>WBR</u>	<u>TOTAL</u>
2010:	39	369	22	47	631	324	256	69	35	20	38	27	1,877
2012:	40	376	22	48	644	331	261	70	36	20	39	28	1,915
Seasonal:	46	433	26	55	740	380	300	81	41	23	45	32	2,202

12: Washington Street / Avenue 52

PHF:	0.894												
Date:	5/25/2010												
	<u>NBL</u>	<u>NBT</u>	<u>NBR</u>	<u>SBL</u>	<u>SBT</u>	<u>SBR</u>	<u>EBL</u>	<u>EBT</u>	<u>EBR</u>	<u>WBL</u>	<u>WBT</u>	<u>WBR</u>	<u>TOTAL</u>
2010:	0	13	9	186	15	431	252	221	4	4	299	135	1,569
2012:	0	13	9	190	15	440	257	225	4	4	305	138	1,601
Seasonal:	0	15	11	218	18	506	296	259	5	5	351	158	1,841

* In accordance with the City of La Quinta's traffic study guidelines (Engineering Bulletin #06-13, revised September 10, 2010), traffic counts should consider the seasonal population variations within the City. Traffic counts conducted during the off-season period of May shall be increase by 15% and 10% for October. However, the "seasonal" volumes include the increase of 2% to 2010 traffic counts and the application of a 15% seasonal factor.

City of La Quinta
 N/S: Avenida Navarro
 E/W: Avenida Montezuma
 Weather: Sunny

File Name : LQAANAMAM
 Site Code : 10122138
 Start Date : 5/25/2010
 Page No : 1

Groups Printed- Total Volume

Start Time	Avenida Navarro Southbound				Avenida Montezuma Westbound				Avenida Navarro Northbound				Avenida Montezuma Eastbound				Int. Total
	Left	Thru	Right	App. Total	Left	Thru	Right	App. Total	Left	Thru	Right	App. Total	Left	Thru	Right	App. Total	
06:00 AM	0	0	0	0	0	3	1	4	0	2	2	4	0	1	0	1	9
06:15 AM	0	0	0	0	0	1	2	3	0	3	2	5	0	10	2	12	20
06:30 AM	0	1	0	1	0	5	1	6	0	7	4	11	3	10	0	13	31
06:45 AM	1	1	0	2	0	6	1	7	0	4	2	6	5	10	2	17	32
Total	1	2	0	3	0	15	5	20	0	16	10	26	8	31	4	43	92
07:00 AM	0	0	0	0	0	7	1	8	0	5	2	7	1	17	0	18	33
07:15 AM	1	0	0	1	0	2	1	3	0	9	5	14	3	14	1	18	36
07:30 AM	0	0	0	0	4	5	0	9	0	8	3	11	1	15	0	16	36
07:45 AM	2	0	0	2	5	4	0	9	1	9	4	14	1	25	1	27	52
Total	3	0	0	3	9	18	2	29	1	31	14	46	6	71	2	79	157
08:00 AM	1	0	0	1	0	3	1	4	0	7	3	10	0	18	0	18	33
08:15 AM	1	0	0	1	3	11	0	14	2	11	8	21	1	9	1	11	47
Grand Total	6	2	0	8	12	47	8	67	3	65	35	103	15	129	7	151	329
Apprch %	75	25	0		17.9	70.1	11.9		2.9	63.1	34		9.9	85.4	4.6		
Total %	1.8	0.6	0	2.4	3.6	14.3	2.4	20.4	0.9	19.8	10.6	31.3	4.6	39.2	2.1	45.9	

Start Time	Avenida Navarro Southbound				Avenida Montezuma Westbound				Avenida Navarro Northbound				Avenida Montezuma Eastbound				Int. Total
	Left	Thru	Right	App. Total	Left	Thru	Right	App. Total	Left	Thru	Right	App. Total	Left	Thru	Right	App. Total	
Peak Hour Analysis From 06:00 AM to 08:15 AM - Peak 1 of 1																	
Peak Hour for Entire Intersection Begins at 07:30 AM																	
07:30 AM	0	0	0	0	4	5	0	9	0	8	3	11	1	15	0	16	36
07:45 AM	2	0	0	2	5	4	0	9	1	9	4	14	1	25	1	27	52
08:00 AM	1	0	0	1	0	3	1	4	0	7	3	10	0	18	0	18	33
08:15 AM	1	0	0	1	3	11	0	14	2	11	8	21	1	9	1	11	47
Total Volume	4	0	0	4	12	23	1	36	3	35	18	56	3	67	2	72	168
% App. Total	100	0	0		33.3	63.9	2.8		5.4	62.5	32.1		4.2	93.1	2.8		
PHF	.500	.000	.000	.500	.600	.523	.250	.643	.375	.795	.563	.667	.750	.670	.500	.667	.808

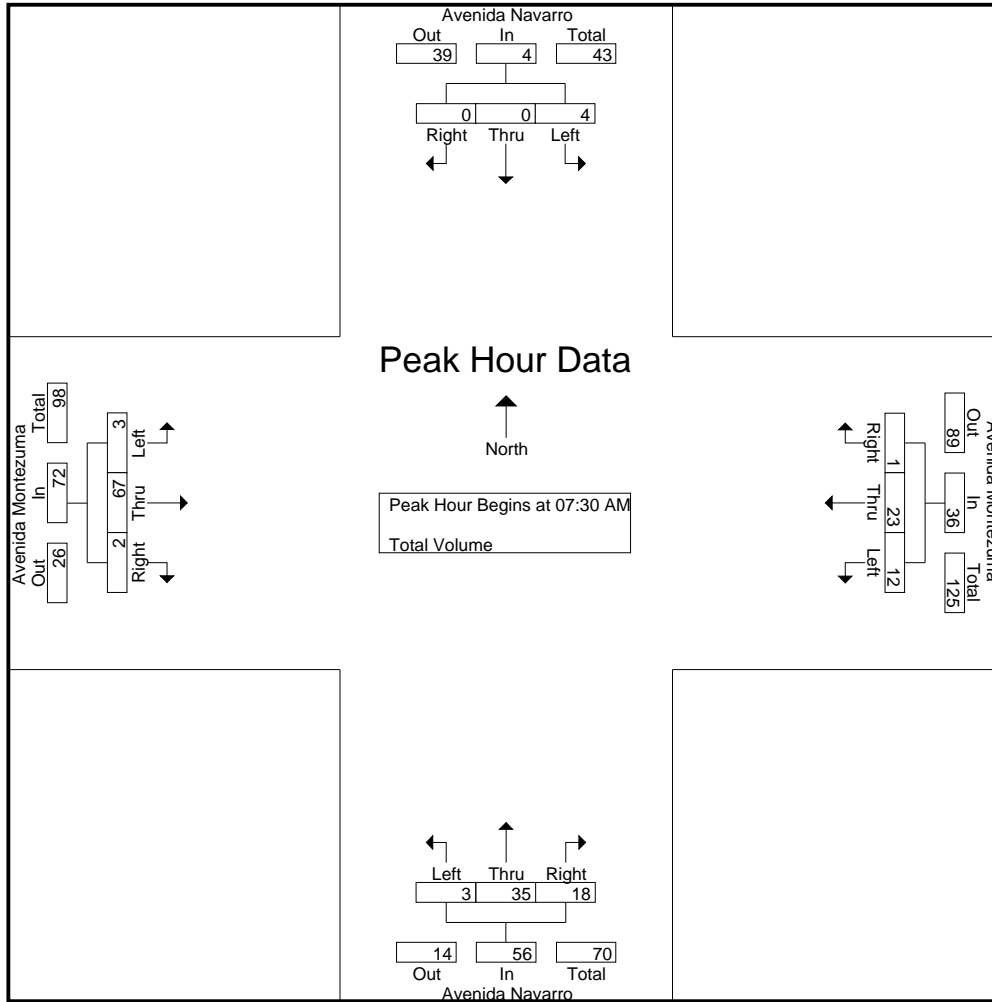

Peak Hour Analysis From 06:00 AM to 08:15 AM - Peak 1 of 1
 Peak Hour for Each Approach Begins at:

	06:30 AM				07:30 AM				07:30 AM				07:00 AM			
+0 mins.	0	1	0	1	4	5	0	9	0	8	3	11	1	17	0	18
+15 mins.	1	1	0	2	5	4	0	9	1	9	4	14	3	14	1	18
+30 mins.	0	0	0	0	0	3	1	4	0	7	3	10	1	15	0	16
+45 mins.	1	0	0	1	3	11	0	14	2	11	8	21	1	25	1	27
Total Volume	2	2	0	4	12	23	1	36	3	35	18	56	6	71	2	79
% App. Total	.50	.50	.00	.50	.33.3	.63.9	.2.8	.643	.5.4	.62.5	.32.1	.667	.7.6	.89.9	.2.5	.731
PHF	.500	.500	.000	.500	.600	.523	.250	.643	.375	.795	.563	.667	.500	.710	.500	.731

City of La Quinta
 N/S: Avenida Bermudas
 E/W:Avenida Montezuma
 Weather: Sunny

File Name : LQAABAMAM
 Site Code : 10122043
 Start Date : 5/25/2010
 Page No : 1

Groups Printed- Total Volume

Start Time	Avenida Bermudas Southbound			Avenida Bermudas Northbound			Avenida Montezuma Eastbound			Int. Total
	Thru	Right	App. Total	Left	Thru	App. Total	Left	Right	App. Total	
06:00 AM	3	0	3	5	2	7	3	1	4	14
06:15 AM	3	4	7	7	5	12	13	5	18	37
06:30 AM	4	4	8	12	5	17	16	7	23	48
06:45 AM	5	6	11	9	6	15	13	8	21	47
Total	15	14	29	33	18	51	45	21	66	146
07:00 AM	9	4	13	14	12	26	20	6	26	65
07:15 AM	6	4	10	6	12	18	24	11	35	63
07:30 AM	12	7	19	4	13	17	16	11	27	63
07:45 AM	13	12	25	2	26	28	19	10	29	82
Total	40	27	67	26	63	89	79	38	117	273
08:00 AM	21	8	29	7	21	28	20	7	27	84
08:15 AM	26	11	37	6	28	34	16	7	23	94
Grand Total	102	60	162	72	130	202	160	73	233	597
Apprch %	63	37		35.6	64.4		68.7	31.3		
Total %	17.1	10.1	27.1	12.1	21.8	33.8	26.8	12.2	39	

Start Time	Avenida Bermudas Southbound			Avenida Bermudas Northbound			Avenida Montezuma Eastbound			Int. Total
	Thru	Right	App. Total	Left	Thru	App. Total	Left	Right	App. Total	
Peak Hour Analysis From 06:00 AM to 08:15 AM - Peak 1 of 1										
Peak Hour for Entire Intersection Begins at 07:30 AM										
07:30 AM	12	7	19	4	13	17	16	11	27	63
07:45 AM	13	12	25	2	26	28	19	10	29	82
08:00 AM	21	8	29	7	21	28	20	7	27	84
08:15 AM	26	11	37	6	28	34	16	7	23	94
Total Volume	72	38	110	19	88	107	71	35	106	323
% App. Total	65.5	34.5		17.8	82.2		67	33		
PHF	.692	.792	.743	.679	.786	.787	.888	.795	.914	.859

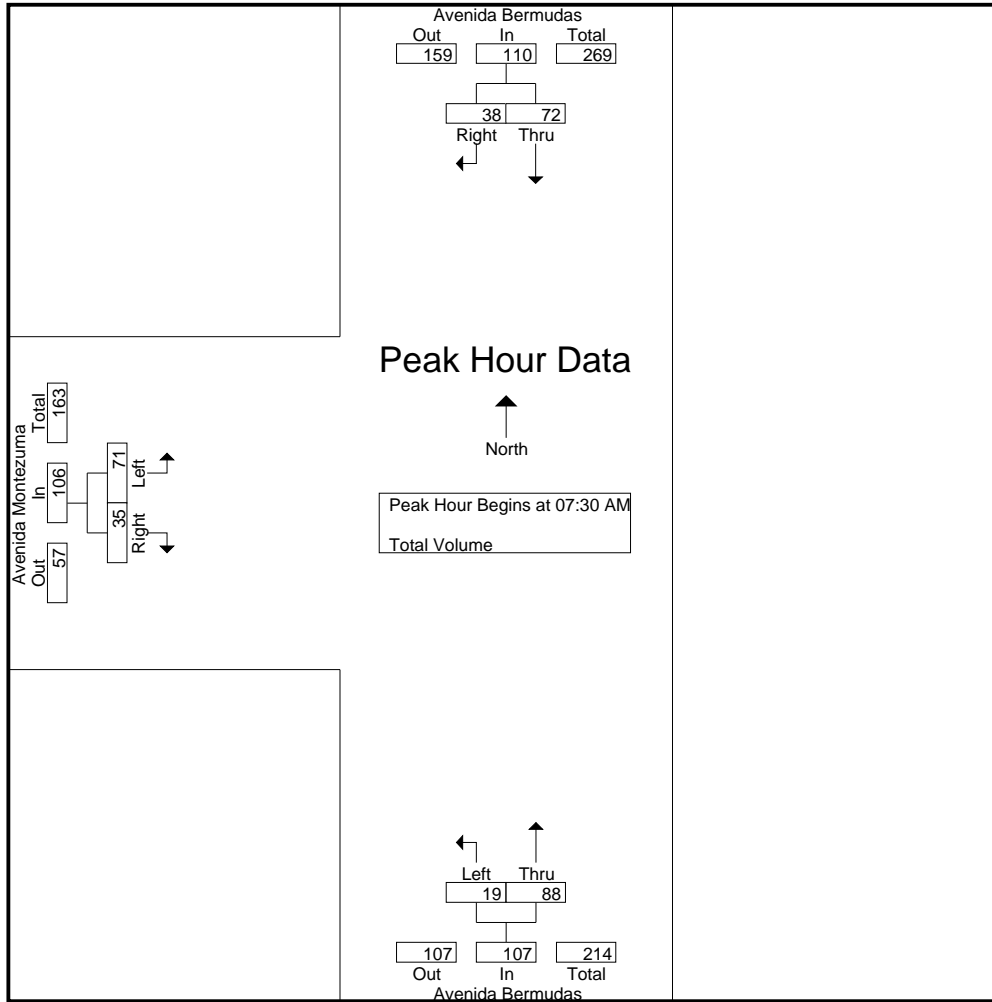

Peak Hour Analysis From 06:00 AM to 08:15 AM - Peak 1 of 1
 Peak Hour for Each Approach Begins at:

	07:30 AM			07:30 AM			07:15 AM		
+0 mins.	12	7	19	4	13	17	24	11	35
+15 mins.	13	12	25	2	26	28	16	11	27
+30 mins.	21	8	29	7	21	28	19	10	29
+45 mins.	26	11	37	6	28	34	20	7	27
Total Volume	72	38	110	19	88	107	79	39	118
% App. Total	65.5	34.5		17.8	82.2		66.9	33.1	
PHF	.692	.792	.743	.679	.786	.787	.823	.886	.843

City of La Quinta
 N/S: Avenida Bermudas
 E/W: Calle Estado
 Weather: Sunny

File Name : LQAABCEAM
 Site Code : 10122043
 Start Date : 5/25/2010
 Page No : 1

Groups Printed- Total Volume

Start Time	Avenida Bermudas Southbound				Calle Estado Westbound				Avenida Bermudas Northbound				Private Driveway Eastbound				Int. Total
	Left	Thru	Right	App. Total	Left	Thru	Right	App. Total	Left	Thru	Right	App. Total	Left	Thru	Right	App. Total	
06:00 AM	0	4	0	4	0	0	1	1	0	5	0	5	0	0	0	0	10
06:15 AM	0	8	0	8	2	0	0	2	0	12	1	13	0	0	0	0	23
06:30 AM	0	9	0	9	0	0	1	1	0	17	1	18	0	0	1	1	29
06:45 AM	1	13	0	14	1	0	0	1	0	15	2	17	0	0	1	1	33
Total	1	34	0	35	3	0	2	5	0	49	4	53	0	0	2	2	95
07:00 AM	1	14	0	15	2	0	4	6	1	23	1	25	0	0	2	2	48
07:15 AM	2	15	0	17	1	0	1	2	1	17	0	18	1	1	3	5	42
07:30 AM	4	19	0	23	4	0	2	6	2	16	0	18	0	0	2	2	49
07:45 AM	4	19	0	23	2	0	0	2	1	28	1	30	0	0	3	3	58
Total	11	67	0	78	9	0	7	16	5	84	2	91	1	1	10	12	197
08:00 AM	1	29	0	30	0	0	3	3	2	26	1	29	0	0	2	2	64
08:15 AM	3	27	0	30	2	0	3	5	1	32	1	34	0	0	2	2	71
Grand Total	16	157	0	173	14	0	15	29	8	191	8	207	1	1	16	18	427
Apprch %	9.2	90.8	0		48.3	0	51.7		3.9	92.3	3.9		5.6	5.6	88.9		
Total %	3.7	36.8	0	40.5	3.3	0	3.5	6.8	1.9	44.7	1.9	48.5	0.2	0.2	3.7	4.2	

Start Time	Avenida Bermudas Southbound				Calle Estado Westbound				Avenida Bermudas Northbound				Private Driveway Eastbound				Int. Total
	Left	Thru	Right	App. Total	Left	Thru	Right	App. Total	Left	Thru	Right	App. Total	Left	Thru	Right	App. Total	
Peak Hour Analysis From 06:00 AM to 08:15 AM - Peak 1 of 1																	
Peak Hour for Entire Intersection Begins at 07:30 AM																	
07:30 AM	4	19	0	23	4	0	2	6	2	16	0	18	0	0	2	2	49
07:45 AM	4	19	0	23	2	0	0	2	1	28	1	30	0	0	3	3	58
08:00 AM	1	29	0	30	0	0	3	3	2	26	1	29	0	0	2	2	64
08:15 AM	3	27	0	30	2	0	3	5	1	32	1	34	0	0	2	2	71
Total Volume	12	94	0	106	8	0	8	16	6	102	3	111	0	0	9	9	242
% App. Total	11.3	88.7	0		50	0	50		5.4	91.9	2.7		0	0	100		
PHF	.750	.810	.000	.883	.500	.000	.667	.667	.750	.797	.750	.816	.000	.000	.750	.750	.852

City of La Quinta
 N/S: Avenida Bermudas
 E/W: Calle Estado
 Weather: Sunny

File Name : LQAABCEAM
 Site Code : 10122043
 Start Date : 5/25/2010
 Page No : 2

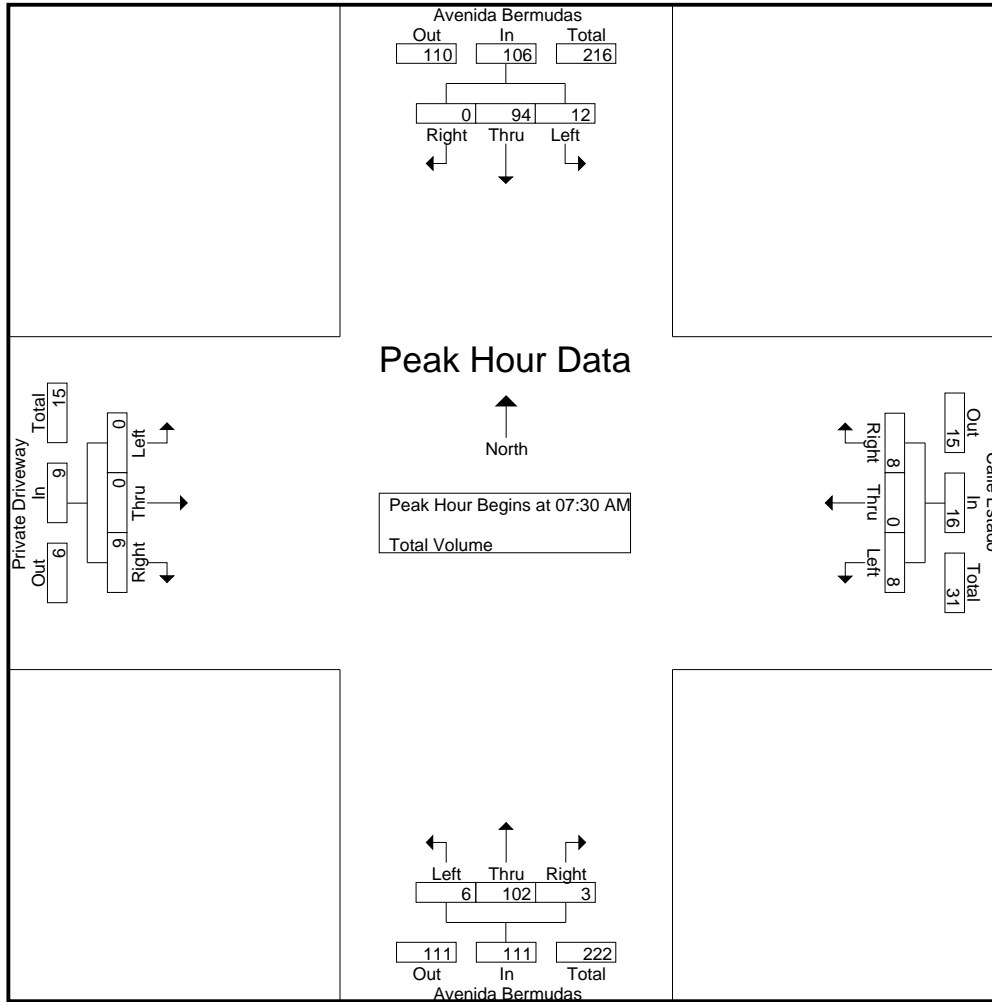

Peak Hour Analysis From 06:00 AM to 08:15 AM - Peak 1 of 1
 Peak Hour for Each Approach Begins at:

	07:30 AM				07:00 AM				07:30 AM				07:00 AM			
+0 mins.	4	19	0	23	2	0	4	6	2	16	0	18	0	0	2	2
+15 mins.	4	19	0	23	1	0	1	2	1	28	1	30	1	1	3	5
+30 mins.	1	29	0	30	4	0	2	6	2	26	1	29	0	0	2	2
+45 mins.	3	27	0	30	2	0	0	2	1	32	1	34	0	0	3	3
Total Volume	12	94	0	106	9	0	7	16	6	102	3	111	1	1	10	12
% App. Total	11.3	88.7	0		56.2	0	43.8		5.4	91.9	2.7		8.3	8.3	83.3	
PHF	.750	.810	.000	.883	.563	.000	.438	.667	.750	.797	.750	.816	.250	.250	.833	.600

City of La Quinta
 N/S: Avenida Bermudas
 E/W: Avenue 52 / Calle Sinaloa
 Weather: Sunny

File Name : LQAABCSAM
 Site Code : 10122139
 Start Date : 5/25/2010
 Page No : 1

Groups Printed- Total Volume

Start Time	Avenida Bermudas Southbound				Avenue 52 Westbound				Avenida Bermudas Northbound				Calle Sinaloa Eastbound				Int. Total
	Left	Thru	Right	App. Total	Left	Thru	Right	App. Total	Left	Thru	Right	App. Total	Left	Thru	Right	App. Total	
06:00 AM	1	2	0	3	9	13	0	22	0	4	56	60	1	26	0	27	112
06:15 AM	3	1	3	7	22	15	3	40	0	8	84	92	1	30	1	32	171
06:30 AM	5	1	1	7	14	22	1	37	1	13	122	136	6	48	1	55	235
06:45 AM	8	2	4	14	18	19	2	39	1	11	127	139	4	38	0	42	234
Total	17	6	8	31	63	69	6	138	2	36	389	427	12	142	2	156	752
07:00 AM	6	8	4	18	29	24	4	57	0	13	182	195	6	94	0	100	370
07:15 AM	8	3	2	13	32	35	3	70	1	15	217	233	4	90	2	96	412
07:30 AM	6	10	5	21	44	42	6	92	2	19	195	216	3	76	0	79	408
07:45 AM	9	6	1	16	41	49	7	97	1	19	196	216	4	57	1	62	391
Total	29	27	12	68	146	150	20	316	4	66	790	860	17	317	3	337	1581
08:00 AM	6	13	8	27	44	46	10	100	2	18	142	162	6	57	1	64	353
08:15 AM	7	12	7	26	45	48	8	101	1	26	101	128	3	38	1	42	297
Grand Total	59	58	35	152	298	313	44	655	9	146	1422	1577	38	554	7	599	2983
Apprch %	38.8	38.2	23		45.5	47.8	6.7		0.6	9.3	90.2		6.3	92.5	1.2		
Total %	2	1.9	1.2	5.1	10	10.5	1.5	22	0.3	4.9	47.7	52.9	1.3	18.6	0.2	20.1	

Start Time	Avenida Bermudas Southbound				Avenue 52 Westbound				Avenida Bermudas Northbound				Calle Sinaloa Eastbound				Int. Total
	Left	Thru	Right	App. Total	Left	Thru	Right	App. Total	Left	Thru	Right	App. Total	Left	Thru	Right	App. Total	
Peak Hour Analysis From 06:00 AM to 08:15 AM - Peak 1 of 1																	
Peak Hour for Entire Intersection Begins at 07:00 AM																	
07:00 AM	6	8	4	18	29	24	4	57	0	13	182	195	6	94	0	100	370
07:15 AM	8	3	2	13	32	35	3	70	1	15	217	233	4	90	2	96	412
07:30 AM	6	10	5	21	44	42	6	92	2	19	195	216	3	76	0	79	408
07:45 AM	9	6	1	16	41	49	7	97	1	19	196	216	4	57	1	62	391
Total Volume	29	27	12	68	146	150	20	316	4	66	790	860	17	317	3	337	1581
% App. Total	42.6	39.7	17.6		46.2	47.5	6.3		0.5	7.7	91.9		5	94.1	0.9		
PHF	.806	.675	.600	.810	.830	.765	.714	.814	.500	.868	.910	.923	.708	.843	.375	.843	.959

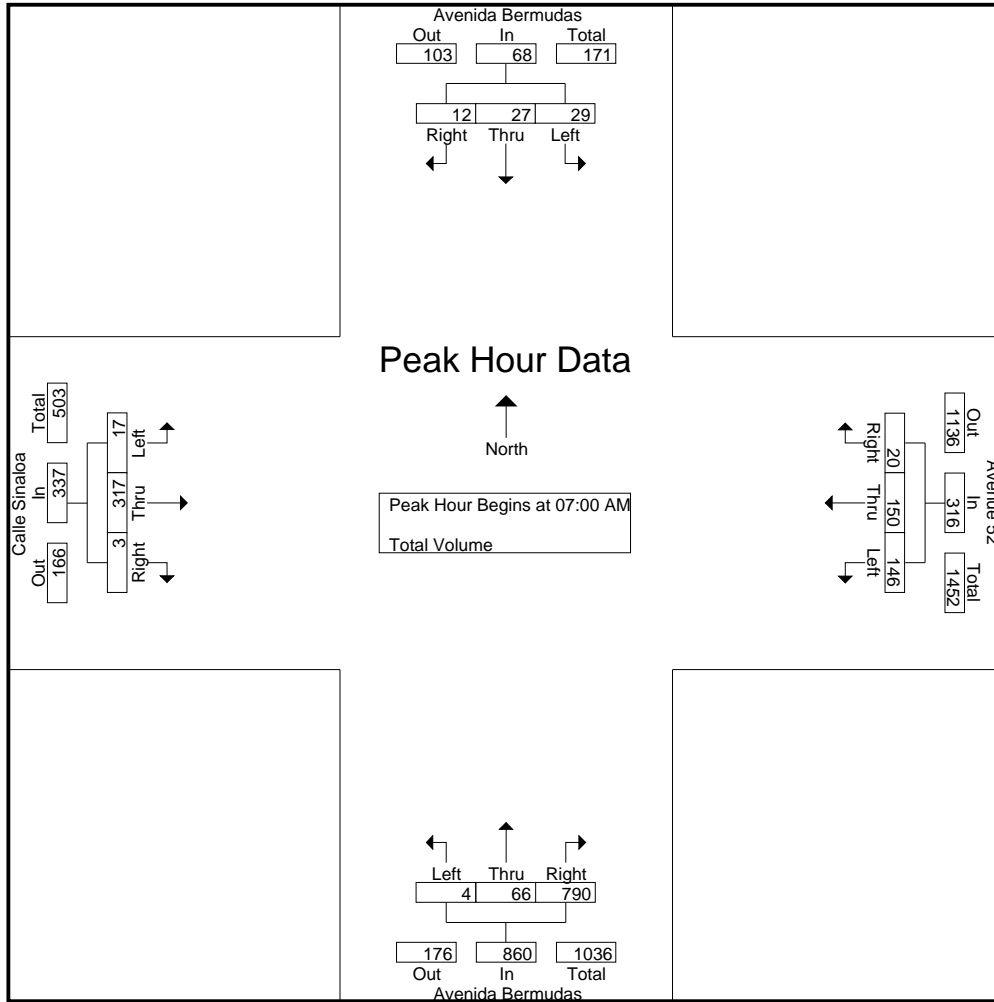

Peak Hour Analysis From 06:00 AM to 08:15 AM - Peak 1 of 1
 Peak Hour for Each Approach Begins at:

	07:30 AM				07:30 AM				07:00 AM				07:00 AM			
+0 mins.	6	10	5	21	44	42	6	92	0	13	182	195	6	94	0	100
+15 mins.	9	6	1	16	41	49	7	97	1	15	217	233	4	90	2	96
+30 mins.	6	13	8	27	44	46	10	100	2	19	195	216	3	76	0	79
+45 mins.	7	12	7	26	45	48	8	101	1	19	196	216	4	57	1	62
Total Volume	28	41	21	90	174	185	31	390	4	66	790	860	17	317	3	337
% App. Total	31.1	45.6	23.3		44.6	47.4	7.9		0.5	7.7	91.9		5	94.1	0.9	
PHF	.778	.788	.656	.833	.967	.944	.775	.965	.500	.868	.910	.923	.708	.843	.375	.843

City of La Quinta
 N/S: Washington Street
 E/W: Eisenhower Drive
 Weather: Sunny

File Name : LQAWAEIAM
 Site Code : 10122
 Start Date : 5/25/2010
 Page No : 1

Groups Printed- Total Volume

Start Time	Washington Street Southbound				Eisenhower Drive Westbound				Washington Street Northbound				Eisenhower Drive Eastbound				Int. Total
	Left	Thru	Right	App. Total	Left	Thru	Right	App. Total	Left	Thru	Right	App. Total	Left	Thru	Right	App. Total	
06:00 AM	6	34	3	43	8	13	16	37	0	94	3	97	6	8	1	15	192
06:15 AM	5	40	3	48	6	10	12	28	7	113	3	123	8	7	3	18	217
06:30 AM	17	48	6	71	6	22	30	58	4	165	11	180	17	21	3	41	350
06:45 AM	21	103	3	127	7	19	29	55	5	200	14	219	18	11	5	34	435
Total	49	225	15	289	27	64	87	178	16	572	31	619	49	47	12	108	1194
07:00 AM	38	89	5	132	22	24	56	102	1	237	24	262	29	27	4	60	556
07:15 AM	33	138	9	180	31	26	67	124	4	251	15	270	41	33	4	78	652
07:30 AM	17	162	7	186	50	31	71	152	19	278	19	316	45	23	33	101	755
07:45 AM	0	317	13	330	38	21	3	62	38	176	13	227	44	33	83	160	779
Total	88	706	34	828	141	102	197	440	62	942	71	1075	159	116	124	399	2742
08:00 AM	3	216	17	236	47	45	8	100	49	134	12	195	22	34	64	120	651
08:15 AM	3	207	18	228	32	20	6	58	36	182	10	228	29	31	66	126	640
Grand Total	143	1354	84	1581	247	231	298	776	163	1830	124	2117	259	228	266	753	5227
Apprch %	9	85.6	5.3		31.8	29.8	38.4		7.7	86.4	5.9		34.4	30.3	35.3		
Total %	2.7	25.9	1.6	30.2	4.7	4.4	5.7	14.8	3.1	35	2.4	40.5	5	4.4	5.1	14.4	

Start Time	Washington Street Southbound				Eisenhower Drive Westbound				Washington Street Northbound				Eisenhower Drive Eastbound				Int. Total
	Left	Thru	Right	App. Total	Left	Thru	Right	App. Total	Left	Thru	Right	App. Total	Left	Thru	Right	App. Total	
Peak Hour Analysis From 06:00 AM to 08:15 AM - Peak 1 of 1																	
Peak Hour for Entire Intersection Begins at 07:15 AM																	
07:15 AM	33	138	9	180	31	26	67	124	4	251	15	270	41	33	4	78	652
07:30 AM	17	162	7	186	50	31	71	152	19	278	19	316	45	23	33	101	755
07:45 AM	0	317	13	330	38	21	3	62	38	176	13	227	44	33	83	160	779
08:00 AM	3	216	17	236	47	45	8	100	49	134	12	195	22	34	64	120	651
Total Volume	53	833	46	932	166	123	149	438	110	839	59	1008	152	123	184	459	2837
% App. Total	5.7	89.4	4.9		37.9	28.1	34		10.9	83.2	5.9		33.1	26.8	40.1		
PHF	.402	.657	.676	.706	.830	.683	.525	.720	.561	.754	.776	.797	.844	.904	.554	.717	.910

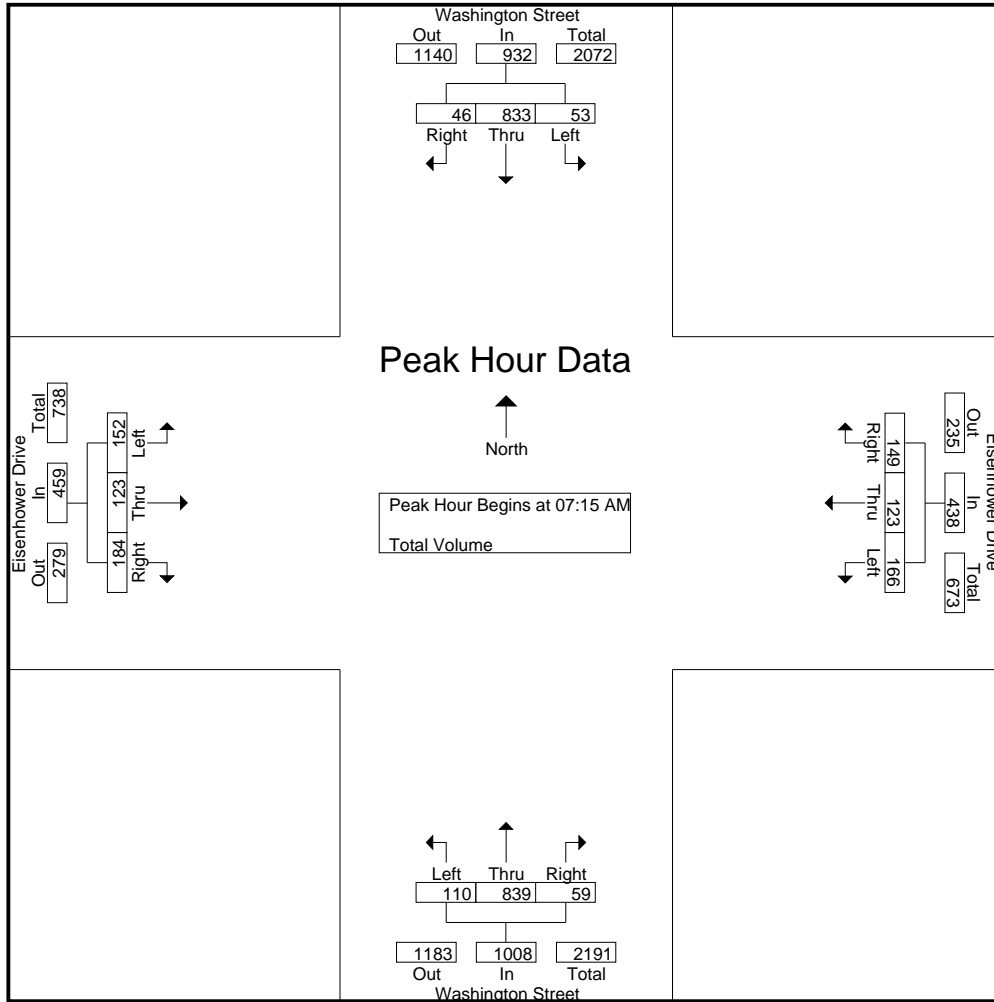

Peak Hour Analysis From 06:00 AM to 08:15 AM - Peak 1 of 1
 Peak Hour for Each Approach Begins at:

	07:30 AM				07:00 AM				07:00 AM				07:30 AM			
+0 mins.	17	162	7	186	22	24	56	102	1	237	24	262	45	23	33	101
+15 mins.	0	317	13	330	31	26	67	124	4	251	15	270	44	33	83	160
+30 mins.	3	216	17	236	50	31	71	152	19	278	19	316	22	34	64	120
+45 mins.	3	207	18	228	38	21	3	62	38	176	13	227	29	31	66	126
Total Volume	23	902	55	980	141	102	197	440	62	942	71	1075	140	121	246	507
% App. Total	2.3	92	5.6		32	23.2	44.8		5.8	87.6	6.6		27.6	23.9	48.5	
PHF	.338	.711	.764	.742	.705	.823	.694	.724	.408	.847	.740	.850	.778	.890	.741	.792

City of La Quinta
 N/S: Washington Street
 E/W: Calle Tampico
 Weather: Sunny

File Name : LQAWACTAM
 Site Code : 10122099
 Start Date : 5/25/2010
 Page No : 1

Groups Printed- Total Volume

Start Time	Washington Street Southbound				Calle Tampico Westbound				Washington Street Northbound				Calle Tampico Eastbound				Int. Total
	Left	Thru	Right	App. Total	Left	Thru	Right	App. Total	Left	Thru	Right	App. Total	Left	Thru	Right	App. Total	
06:00 AM	0	30	9	39	1	4	2	7	1	61	1	63	12	3	3	18	127
06:15 AM	4	32	15	51	0	3	5	8	4	88	1	93	14	7	2	23	175
06:30 AM	3	25	23	51	3	9	9	21	1	150	2	153	24	5	3	32	257
06:45 AM	4	54	18	76	1	5	7	13	6	130	12	148	28	14	2	44	281
Total	11	141	65	217	5	21	23	49	12	429	16	457	78	29	10	117	840
07:00 AM	1	38	3	42	13	7	11	31	6	120	28	154	16	26	1	43	270
07:15 AM	8	63	20	91	17	16	10	43	1	125	43	169	37	21	3	61	364
07:30 AM	5	76	69	150	11	21	18	50	11	227	14	252	70	17	12	99	551
07:45 AM	4	93	88	185	5	27	10	42	14	151	6	171	68	13	11	92	490
Total	18	270	180	468	46	71	49	166	32	623	91	746	191	77	27	295	1675
08:00 AM	8	77	71	156	6	13	14	33	11	150	13	174	77	16	5	98	461
08:15 AM	9	107	79	195	6	11	12	29	6	101	11	118	64	6	6	76	418
Grand Total	46	595	395	1036	63	116	98	277	61	1303	131	1495	410	128	48	586	3394
Apprch %	4.4	57.4	38.1		22.7	41.9	35.4		4.1	87.2	8.8		70	21.8	8.2		
Total %	1.4	17.5	11.6	30.5	1.9	3.4	2.9	8.2	1.8	38.4	3.9	44	12.1	3.8	1.4	17.3	

Start Time	Washington Street Southbound				Calle Tampico Westbound				Washington Street Northbound				Calle Tampico Eastbound				Int. Total
	Left	Thru	Right	App. Total	Left	Thru	Right	App. Total	Left	Thru	Right	App. Total	Left	Thru	Right	App. Total	
Peak Hour Analysis From 06:00 AM to 08:15 AM - Peak 1 of 1																	
Peak Hour for Entire Intersection Begins at 07:30 AM																	
07:30 AM	5	76	69	150	11	21	18	50	11	227	14	252	70	17	12	99	551
07:45 AM	4	93	88	185	5	27	10	42	14	151	6	171	68	13	11	92	490
08:00 AM	8	77	71	156	6	13	14	33	11	150	13	174	77	16	5	98	461
08:15 AM	9	107	79	195	6	11	12	29	6	101	11	118	64	6	6	76	418
Total Volume	26	353	307	686	28	72	54	154	42	629	44	715	279	52	34	365	1920
% App. Total	3.8	51.5	44.8		18.2	46.8	35.1		5.9	88	6.2		76.4	14.2	9.3		
PHF	.722	.825	.872	.879	.636	.667	.750	.770	.750	.693	.786	.709	.906	.765	.708	.922	.871

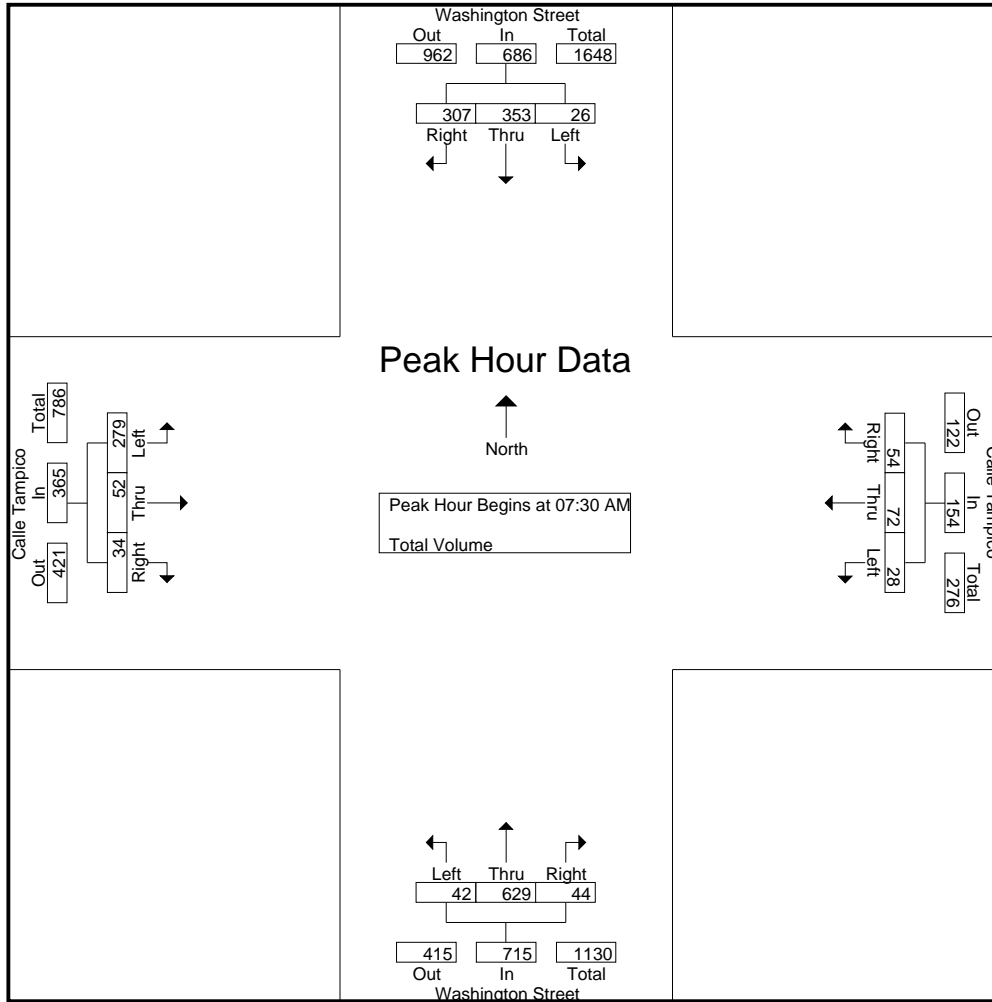

Peak Hour Analysis From 06:00 AM to 08:15 AM - Peak 1 of 1
 Peak Hour for Each Approach Begins at:

	07:30 AM				07:15 AM				07:15 AM				07:30 AM			
+0 mins.	5	76	69	150	17	16	10	43	1	125	43	169	70	17	12	99
+15 mins.	4	93	88	185	11	21	18	50	11	227	14	252	68	13	11	92
+30 mins.	8	77	71	156	5	27	10	42	14	151	6	171	77	16	5	98
+45 mins.	9	107	79	195	6	13	14	33	11	150	13	174	64	6	6	76
Total Volume	26	353	307	686	39	77	52	168	37	653	76	766	279	52	34	365
% App. Total	3.8	51.5	44.8		23.2	45.8	31		4.8	85.2	9.9		76.4	14.2	9.3	
PHF	.722	.825	.872	.879	.574	.713	.722	.840	.661	.719	.442	.760	.906	.765	.708	.922

City of La Quinta
 N/S: Washington Street
 E/W: 52nd Avenue
 Weather: Sunny

File Name : LQAWA52AM
 Site Code : 10122031
 Start Date : 5/25/2010
 Page No : 1

Groups Printed- Total Volume

Start Time	Washington Street Southbound				52nd Avenue Westbound				Washington Street Northbound				52nd Avenue Eastbound				Int. Total
	Left	Thru	Right	App. Total	Left	Thru	Right	App. Total	Left	Thru	Right	App. Total	Left	Thru	Right	App. Total	
05:15 AM	9	3	11	23	3	17	15	35	0	1	0	1	52	27	2	81	140
05:30 AM	18	0	25	43	3	16	32	51	0	4	0	4	66	54	1	121	219
05:45 AM	20	1	9	30	3	27	39	69	0	0	0	0	94	60	0	154	253
Total	47	4	45	96	9	60	86	155	0	5	0	5	212	141	3	356	612
06:00 AM	30	4	23	57	3	22	34	59	0	4	0	4	120	81	0	201	321
06:15 AM	32	2	30	64	6	34	36	76	1	1	2	4	182	87	0	269	413
06:30 AM	41	2	46	89	9	30	41	80	0	2	1	3	210	86	0	296	468
06:45 AM	41	2	44	87	2	43	59	104	0	7	1	8	183	90	0	273	472
Total	144	10	143	297	20	129	170	319	1	14	4	19	695	344	0	1039	1674
07:00 AM	56	2	49	107	5	47	60	112	1	0	0	1	154	81	0	235	455
07:15 AM	37	4	44	85	8	54	48	110	2	2	0	4	116	70	0	186	385
07:30 AM	53	3	59	115	2	40	37	79	2	4	1	7	87	51	0	138	339
Grand Total	337	23	340	700	44	330	401	775	6	25	5	36	1264	687	3	1954	3465
Apprch %	48.1	3.3	48.6		5.7	42.6	51.7		16.7	69.4	13.9		64.7	35.2	0.2		
Total %	9.7	0.7	9.8	20.2	1.3	9.5	11.6	22.4	0.2	0.7	0.1	1	36.5	19.8	0.1	56.4	

Start Time	Washington Street Southbound				52nd Avenue Westbound				Washington Street Northbound				52nd Avenue Eastbound				Int. Total
	Left	Thru	Right	App. Total	Left	Thru	Right	App. Total	Left	Thru	Right	App. Total	Left	Thru	Right	App. Total	
Peak Hour Analysis From 05:15 AM to 07:30 AM - Peak 1 of 1																	
Peak Hour for Entire Intersection Begins at 06:15 AM																	
06:15 AM	32	2	30	64	6	34	36	76	1	1	2	4	182	87	0	269	413
06:30 AM	41	2	46	89	9	30	41	80	0	2	1	3	210	86	0	296	468
06:45 AM	41	2	44	87	2	43	59	104	0	7	1	8	183	90	0	273	472
07:00 AM	56	2	49	107	5	47	60	112	1	0	0	1	154	81	0	235	455
Total Volume	170	8	169	347	22	154	196	372	2	10	4	16	729	344	0	1073	1808
% App. Total	49	2.3	48.7		5.9	41.4	52.7		12.5	62.5	25		67.9	32.1	0		
PHF	.759	1.000	.862	.811	.611	.819	.817	.830	.500	.357	.500	.500	.868	.956	.000	.906	.958

City of La Quinta
 N/S: Washington Street
 E/W: 52nd Avenue
 Weather: Sunny

File Name : LQAWA52AM
 Site Code : 10122031
 Start Date : 5/25/2010
 Page No : 2

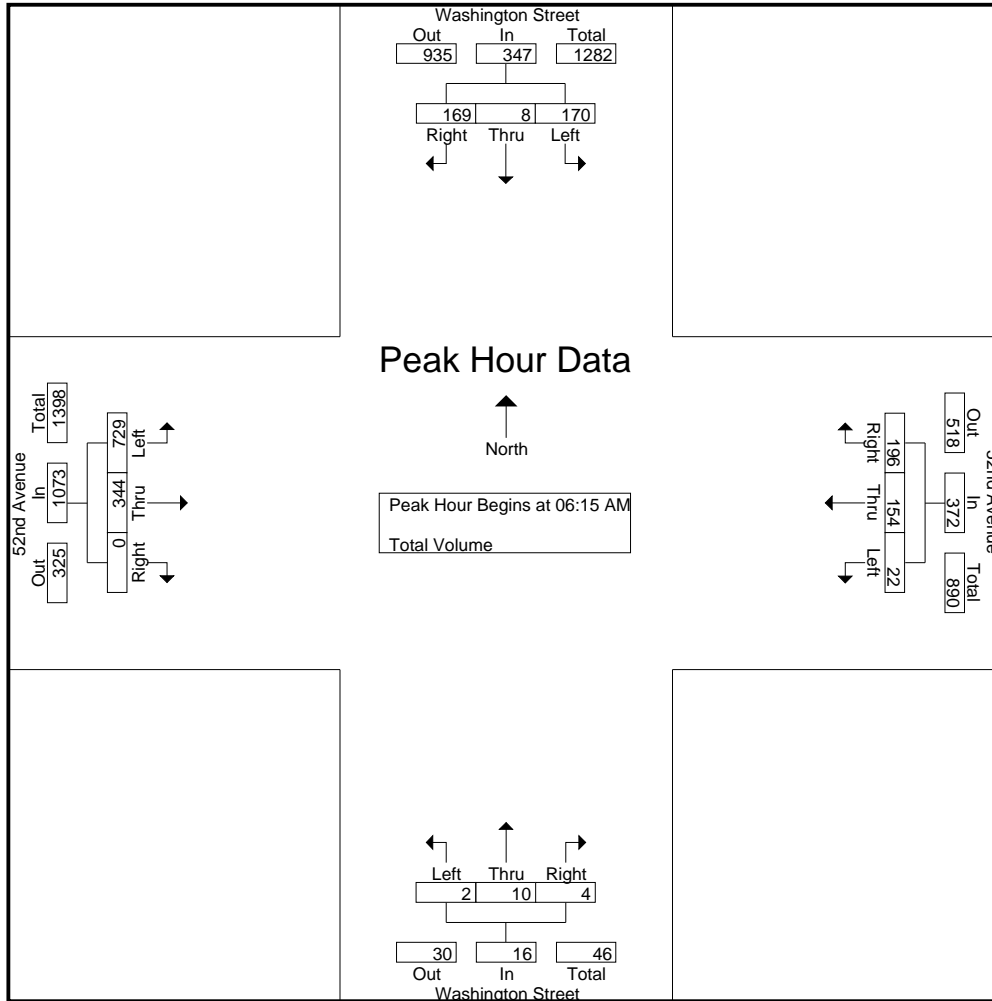

Peak Hour Analysis From 05:15 AM to 07:30 AM - Peak 1 of 1
 Peak Hour for Each Approach Begins at:

	06:45 AM				06:30 AM				06:45 AM				06:15 AM			
+0 mins.	41	2	44	87	9	30	41	80	0	7	1	8	182	87	0	269
+15 mins.	56	2	49	107	2	43	59	104	1	0	0	1	210	86	0	296
+30 mins.	37	4	44	85	5	47	60	112	2	2	0	4	183	90	0	273
+45 mins.	53	3	59	115	8	54	48	110	2	4	1	7	154	81	0	235
Total Volume	187	11	196	394	24	174	208	406	5	13	2	20	729	344	0	1073
% App. Total	47.5	2.8	49.7		5.9	42.9	51.2		25	65	10		67.9	32.1	0	
PHF	.835	.688	.831	.857	.667	.806	.867	.906	.625	.464	.500	.625	.868	.956	.000	.906

City of La Quinta
 N/S: Avenida Navarro
 E/W: Avenida Montezuma
 Weather: Sunny

File Name : LQAANAMPM
 Site Code : 10122031
 Start Date : 5/25/2010
 Page No : 1

Groups Printed- Total Volume

Start Time	Avenida Navarro Southbound				Avenida Montezuma Westbound				Avenida Navarro Northbound				Avenida Montezuma Eastbound				Int. Total
	Left	Thru	Right	App. Total	Left	Thru	Right	App. Total	Left	Thru	Right	App. Total	Left	Thru	Right	App. Total	
02:30 PM	2	1	1	4	4	4	0	8	7	12	7	26	2	17	1	20	58
02:45 PM	2	0	2	4	4	4	2	10	2	6	9	17	3	13	1	17	48
Total	4	1	3	8	8	8	2	18	9	18	16	43	5	30	2	37	106
03:00 PM	1	1	1	3	1	8	1	10	2	3	10	15	2	6	0	8	36
03:15 PM	0	0	0	0	3	5	0	8	5	2	7	14	3	12	3	18	40
03:30 PM	0	0	0	0	4	8	0	12	1	5	8	14	3	9	0	12	38
03:45 PM	0	0	1	1	2	5	1	8	0	4	13	17	2	16	1	19	45
Total	1	1	2	4	10	26	2	38	8	14	38	60	10	43	4	57	159
04:00 PM	0	1	0	1	0	5	0	5	2	10	12	24	3	8	2	13	43
04:15 PM	0	0	2	2	2	6	3	11	3	10	9	22	1	17	4	22	57
04:30 PM	0	0	0	0	2	6	0	8	1	7	7	15	1	4	0	5	28
04:45 PM	2	0	0	2	0	9	1	10	2	8	5	15	2	16	1	19	46
Total	2	1	2	5	4	26	4	34	8	35	33	76	7	45	7	59	174
05:00 PM	0	0	1	1	2	15	1	18	2	4	2	8	1	14	0	15	42
05:15 PM	0	1	0	1	3	10	0	13	2	5	8	15	1	8	1	10	39
Grand Total	7	4	8	19	27	85	9	121	29	76	97	202	24	140	14	178	520
Apprch %	36.8	21.1	42.1		22.3	70.2	7.4		14.4	37.6	48		13.5	78.7	7.9		
Total %	1.3	0.8	1.5	3.7	5.2	16.3	1.7	23.3	5.6	14.6	18.7	38.8	4.6	26.9	2.7	34.2	

Start Time	Avenida Navarro Southbound				Avenida Montezuma Westbound				Avenida Navarro Northbound				Avenida Montezuma Eastbound				Int. Total
	Left	Thru	Right	App. Total	Left	Thru	Right	App. Total	Left	Thru	Right	App. Total	Left	Thru	Right	App. Total	
Peak Hour Analysis From 02:30 PM to 05:15 PM - Peak 1 of 1																	
Peak Hour for Entire Intersection Begins at 03:30 PM																	
03:30 PM	0	0	0	0	4	8	0	12	1	5	8	14	3	9	0	12	38
03:45 PM	0	0	1	1	2	5	1	8	0	4	13	17	2	16	1	19	45
04:00 PM	0	1	0	1	0	5	0	5	2	10	12	24	3	8	2	13	43
04:15 PM	0	0	2	2	2	6	3	11	3	10	9	22	1	17	4	22	57
Total Volume	0	1	3	4	8	24	4	36	6	29	42	77	9	50	7	66	183
% App. Total	0	25	75		22.2	66.7	11.1		7.8	37.7	54.5		13.6	75.8	10.6		
PHF	.000	.250	.375	.500	.500	.750	.333	.750	.500	.725	.808	.802	.750	.735	.438	.750	.803

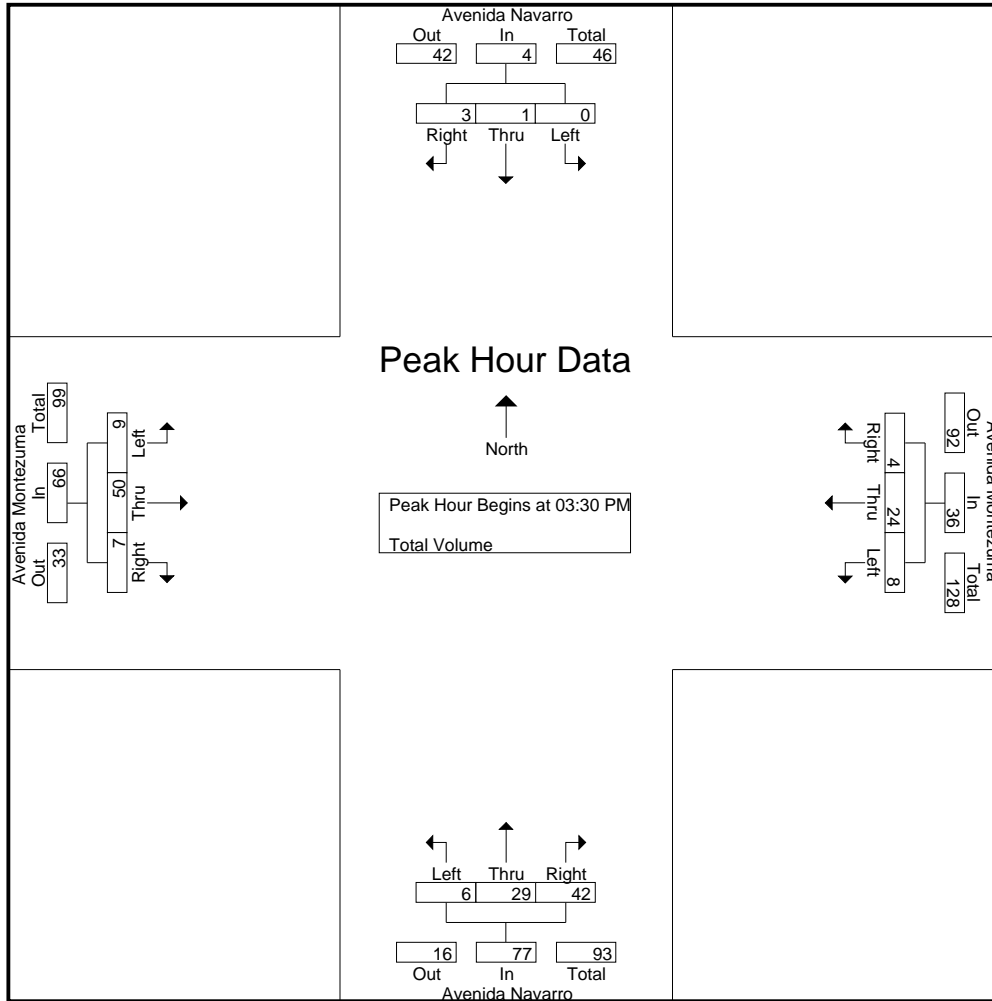

Peak Hour Analysis From 02:30 PM to 05:15 PM - Peak 1 of 1

Peak Hour for Each Approach Begins at:

	02:30 PM				04:30 PM				03:45 PM				03:30 PM			
+0 mins.	2	1	1	4	2	6	0	8	0	4	13	17	3	9	0	12
+15 mins.	2	0	2	4	0	9	1	10	2	10	12	24	2	16	1	19
+30 mins.	1	1	1	3	2	15	1	18	3	10	9	22	3	8	2	13
+45 mins.	0	0	0	0	3	10	0	13	1	7	7	15	1	17	4	22
Total Volume	5	2	4	11	7	40	2	49	6	31	41	78	9	50	7	66
% App. Total	45.5	18.2	36.4		14.3	81.6	4.1		7.7	39.7	52.6		13.6	75.8	10.6	
PHF	.625	.500	.500	.688	.583	.667	.500	.681	.500	.775	.788	.813	.750	.735	.438	.750

City of La Quinta
 N/S: Avenida Bermudas
 E/W: Avenida Montezuma
 Weather: Sunny

File Name : LQAABAMPM
 Site Code : 10122043
 Start Date : 5/25/2010
 Page No : 1

Groups Printed- Total Volume

Start Time	Avenida Bermudas Southbound			Avenida Bermudas Northbound			Avenida Montezuma Eastbound			Int. Total
	Thru	Right	App. Total	Left	Thru	App. Total	Left	Right	App. Total	
02:30 PM	34	11	45	1	16	17	20	9	29	91
02:45 PM	29	6	35	5	22	27	20	11	31	93
Total	63	17	80	6	38	44	40	20	60	184
03:00 PM	30	9	39	5	22	27	19	0	19	85
03:15 PM	35	10	45	0	30	30	10	8	18	93
03:30 PM	38	13	51	2	16	18	17	7	24	93
03:45 PM	36	13	49	2	27	29	20	6	26	104
Total	139	45	184	9	95	104	66	21	87	375
04:00 PM	39	9	48	2	19	21	15	6	21	90
04:15 PM	39	10	49	7	20	27	18	6	24	100
04:30 PM	34	16	50	3	14	17	8	9	17	84
04:45 PM	42	10	52	4	21	25	14	10	24	101
Total	154	45	199	16	74	90	55	31	86	375
05:00 PM	39	11	50	5	16	21	15	6	21	92
05:15 PM	26	11	37	5	20	25	11	4	15	77
Grand Total	421	129	550	41	243	284	187	82	269	1103
Apprch %	76.5	23.5		14.4	85.6		69.5	30.5		
Total %	38.2	11.7	49.9	3.7	22	25.7	17	7.4	24.4	

Start Time	Avenida Bermudas Southbound			Avenida Bermudas Northbound			Avenida Montezuma Eastbound			Int. Total
	Thru	Right	App. Total	Left	Thru	App. Total	Left	Right	App. Total	
03:30 PM	38	13	51	2	16	18	17	7	24	93
03:45 PM	36	13	49	2	27	29	20	6	26	104
04:00 PM	39	9	48	2	19	21	15	6	21	90
04:15 PM	39	10	49	7	20	27	18	6	24	100
Total Volume	152	45	197	13	82	95	70	25	95	387
% App. Total	77.2	22.8		13.7	86.3		73.7	26.3		
PHF	.974	.865	.966	.464	.759	.819	.875	.893	.913	.930

Peak Hour Analysis From 02:30 PM to 05:15 PM - Peak 1 of 1
 Peak Hour for Entire Intersection Begins at 03:30 PM

City of La Quinta
 N/S: Avenida Bermudas
 E/W: Avenida Montezuma
 Weather: Sunny

File Name : LQAABAMPM
 Site Code : 10122043
 Start Date : 5/25/2010
 Page No : 2

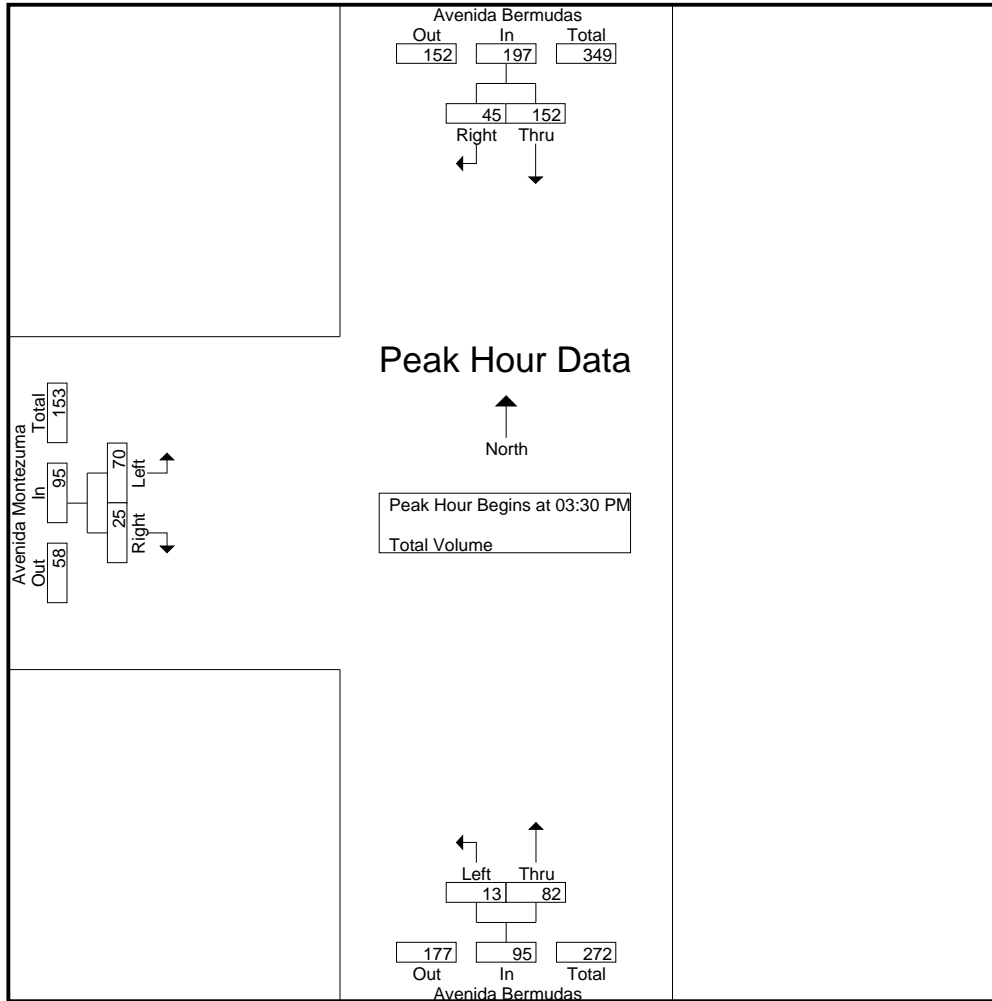

Peak Hour Analysis From 02:30 PM to 05:15 PM - Peak 1 of 1

Peak Hour for Each Approach Begins at:

	04:15 PM			03:00 PM			02:30 PM		
+0 mins.	39	10	49	5	22	27	20	9	29
+15 mins.	34	16	50	0	30	30	20	11	31
+30 mins.	42	10	52	2	16	18	19	0	19
+45 mins.	39	11	50	2	27	29	10	8	18
Total Volume	154	47	201	9	95	104	69	28	97
% App. Total	76.6	23.4		8.7	91.3		71.1	28.9	
PHF	.917	.734	.966	.450	.792	.867	.863	.636	.782

City of La Quinta
 N/S: Avenida Bermudas
 E/W: Calle Estado
 Weather: Sunny

File Name : LQAABCEPM
 Site Code : 10122043
 Start Date : 5/25/2010
 Page No : 1

Groups Printed- Total Volume

Start Time	Avenida Bermudas Southbound				Calle Estado Westbound				Avenida Bermudas Northbound				Private Driveway Eastbound				Int. Total
	Left	Thru	Right	App. Total	Left	Thru	Right	App. Total	Left	Thru	Right	App. Total	Left	Thru	Right	App. Total	
02:30 PM	2	41	0	43	4	0	6	10	3	11	0	14	0	0	4	4	71
02:45 PM	4	36	0	40	10	0	10	20	5	17	0	22	0	0	5	5	87
Total	6	77	0	83	14	0	16	30	8	28	0	36	0	0	9	9	158
03:00 PM	0	30	0	30	7	0	3	10	4	24	3	31	0	0	2	2	73
03:15 PM	5	38	0	43	5	0	8	13	3	22	1	26	0	0	5	5	87
03:30 PM	2	43	0	45	2	0	5	7	4	13	2	19	0	1	2	3	74
03:45 PM	4	38	0	42	3	0	6	9	2	23	1	26	0	0	7	7	84
Total	11	149	0	160	17	0	22	39	13	82	7	102	0	1	16	17	318
04:00 PM	2	43	0	45	2	0	3	5	3	18	3	24	0	1	3	4	78
04:15 PM	1	44	0	45	5	0	4	9	2	23	2	27	0	0	8	8	89
04:30 PM	1	42	0	43	3	0	3	6	3	14	2	19	0	0	7	7	75
04:45 PM	6	46	0	52	2	0	5	7	1	20	1	22	1	0	3	4	85
Total	10	175	0	185	12	0	15	27	9	75	8	92	1	1	21	23	327
05:00 PM	1	44	0	45	1	0	4	5	2	17	0	19	0	0	5	5	74
05:15 PM	1	29	0	30	6	0	4	10	1	21	2	24	0	0	5	5	69
Grand Total	29	474	0	503	50	0	61	111	33	223	17	273	1	2	56	59	946
Apprch %	5.8	94.2	0		45	0	55		12.1	81.7	6.2		1.7	3.4	94.9		
Total %	3.1	50.1	0	53.2	5.3	0	6.4	11.7	3.5	23.6	1.8	28.9	0.1	0.2	5.9	6.2	

Start Time	Avenida Bermudas Southbound				Calle Estado Westbound				Avenida Bermudas Northbound				Private Driveway Eastbound				Int. Total
	Left	Thru	Right	App. Total	Left	Thru	Right	App. Total	Left	Thru	Right	App. Total	Left	Thru	Right	App. Total	
Peak Hour Analysis From 02:30 PM to 05:15 PM - Peak 1 of 1																	
Peak Hour for Entire Intersection Begins at 04:00 PM																	
04:00 PM	2	43	0	45	2	0	3	5	3	18	3	24	0	1	3	4	78
04:15 PM	1	44	0	45	5	0	4	9	2	23	2	27	0	0	8	8	89
04:30 PM	1	42	0	43	3	0	3	6	3	14	2	19	0	0	7	7	75
04:45 PM	6	46	0	52	2	0	5	7	1	20	1	22	1	0	3	4	85
Total Volume	10	175	0	185	12	0	15	27	9	75	8	92	1	1	21	23	327
% App. Total	5.4	94.6	0		44.4	0	55.6		9.8	81.5	8.7		4.3	4.3	91.3		
PHF	.417	.951	.000	.889	.600	.000	.750	.750	.750	.815	.667	.852	.250	.250	.656	.719	.919

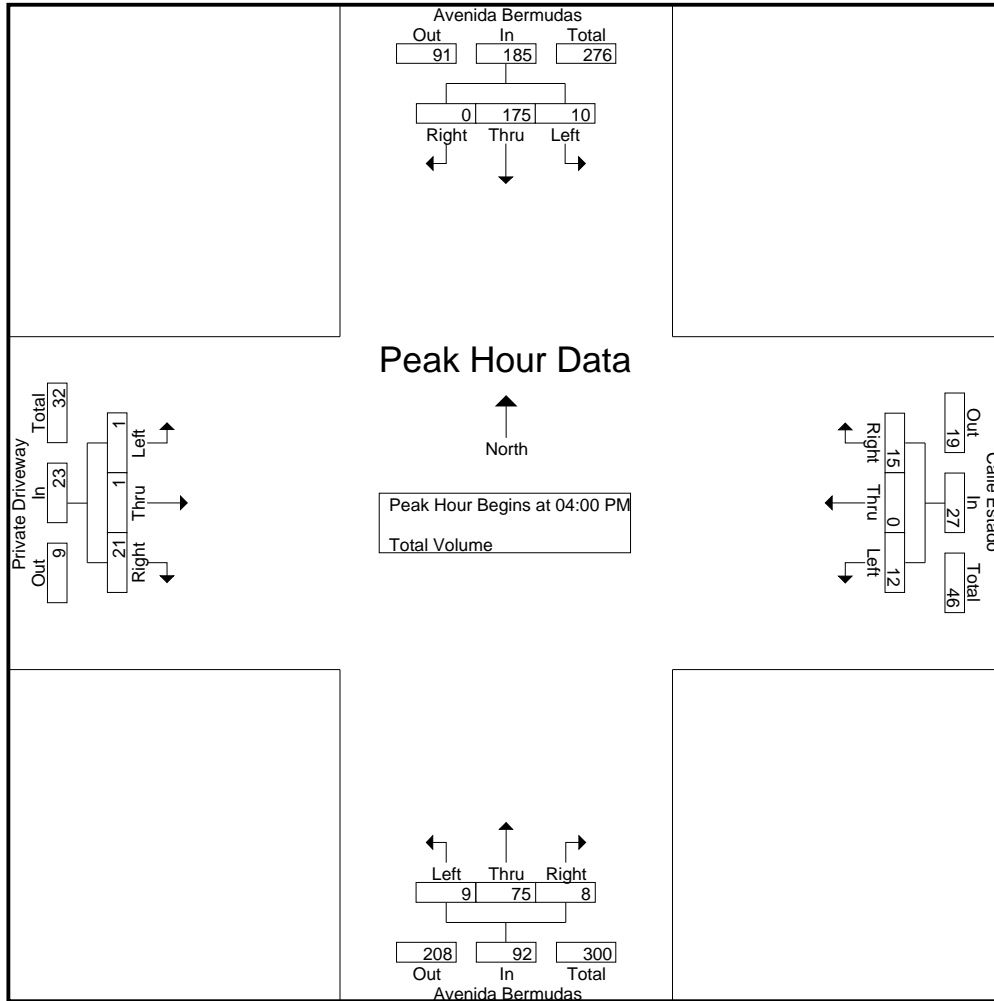

Peak Hour Analysis From 02:30 PM to 05:15 PM - Peak 1 of 1
 Peak Hour for Each Approach Begins at:

	04:00 PM				02:30 PM				03:00 PM				03:45 PM			
+0 mins.	2	43	0	45	4	0	6	10	4	24	3	31	0	0	7	7
+15 mins.	1	44	0	45	10	0	10	20	3	22	1	26	0	1	3	4
+30 mins.	1	42	0	43	7	0	3	10	4	13	2	19	0	0	8	8
+45 mins.	6	46	0	52	5	0	8	13	2	23	1	26	0	0	7	7
Total Volume	10	175	0	185	26	0	27	53	13	82	7	102	0	1	25	26
% App. Total	5.4	94.6	0		49.1	0	50.9		12.7	80.4	6.9		0	3.8	96.2	
PHF	.417	.951	.000	.889	.650	.000	.675	.663	.813	.854	.583	.823	.000	.250	.781	.813

City of La Quinta
 N/S: Avenida Bermudas
 E/W: Avenue 52 / Calle Sinaloa
 Weather: Sunny

File Name : LQAABCSPM
 Site Code : 10122138
 Start Date : 5/25/2010
 Page No : 1

Groups Printed- Total Volume

Start Time	Avenida Bermudas Southbound				Avenue 52 Westbound				Avenida Bermudas Northbound				Calle Sinaloa Eastbound				Int. Total
	Left	Thru	Right	App. Total	Left	Thru	Right	App. Total	Left	Thru	Right	App. Total	Left	Thru	Right	App. Total	
02:30 PM	10	10	7	27	66	58	9	133	1	11	71	83	2	45	1	48	291
02:45 PM	19	11	12	42	72	83	8	163	1	15	82	98	4	37	0	41	344
Total	29	21	19	69	138	141	17	296	2	26	153	181	6	82	1	89	635
03:00 PM	9	13	6	28	77	76	7	160	1	9	70	80	3	44	1	48	316
03:15 PM	8	14	13	35	81	83	13	177	1	9	77	87	8	38	0	46	345
03:30 PM	4	17	10	31	86	65	4	155	1	10	75	86	4	36	0	40	312
03:45 PM	6	22	5	33	119	84	9	212	1	15	69	85	8	41	0	49	379
Total	27	66	34	127	363	308	33	704	4	43	291	338	23	159	1	183	1352
04:00 PM	5	17	6	28	71	77	7	155	0	15	52	67	7	25	1	33	283
04:15 PM	7	15	8	30	133	94	8	235	0	11	70	81	4	38	1	43	389
04:30 PM	10	23	9	42	140	70	3	213	0	10	92	102	6	47	0	53	410
04:45 PM	3	22	9	34	104	102	4	210	0	10	78	88	5	36	2	43	375
Total	25	77	32	134	448	343	22	813	0	46	292	338	22	146	4	172	1457
05:00 PM	6	24	12	42	110	80	8	198	0	12	69	81	4	33	1	38	359
05:15 PM	2	17	10	29	111	103	7	221	0	10	77	87	4	54	2	60	397
Grand Total	89	205	107	401	1170	975	87	2232	6	137	882	1025	59	474	9	542	4200
Apprch %	22.2	51.1	26.7		52.4	43.7	3.9		0.6	13.4	8.6		10.9	87.5	1.7		
Total %	2.1	4.9	2.5	9.5	27.9	23.2	2.1	53.1	0.1	3.3	2.1	24.4	1.4	11.3	0.2	12.9	

Start Time	Avenida Bermudas Southbound				Avenue 52 Westbound				Avenida Bermudas Northbound				Calle Sinaloa Eastbound				Int. Total
	Left	Thru	Right	App. Total	Left	Thru	Right	App. Total	Left	Thru	Right	App. Total	Left	Thru	Right	App. Total	
Peak Hour Analysis From 02:30 PM to 05:15 PM - Peak 1 of 1																	
Peak Hour for Entire Intersection Begins at 04:30 PM																	
04:30 PM	10	23	9	42	140	70	3	213	0	10	92	102	6	47	0	53	410
04:45 PM	3	22	9	34	104	102	4	210	0	10	78	88	5	36	2	43	375
05:00 PM	6	24	12	42	110	80	8	198	0	12	69	81	4	33	1	38	359
05:15 PM	2	17	10	29	111	103	7	221	0	10	77	87	4	54	2	60	397
Total Volume	21	86	40	147	465	355	22	842	0	42	316	358	19	170	5	194	1541
% App. Total	14.3	58.5	27.2		55.2	42.2	2.6		0	11.7	88.3		9.8	87.6	2.6		
PHF	.525	.896	.833	.875	.830	.862	.688	.952	.000	.875	.859	.877	.792	.787	.625	.808	.940

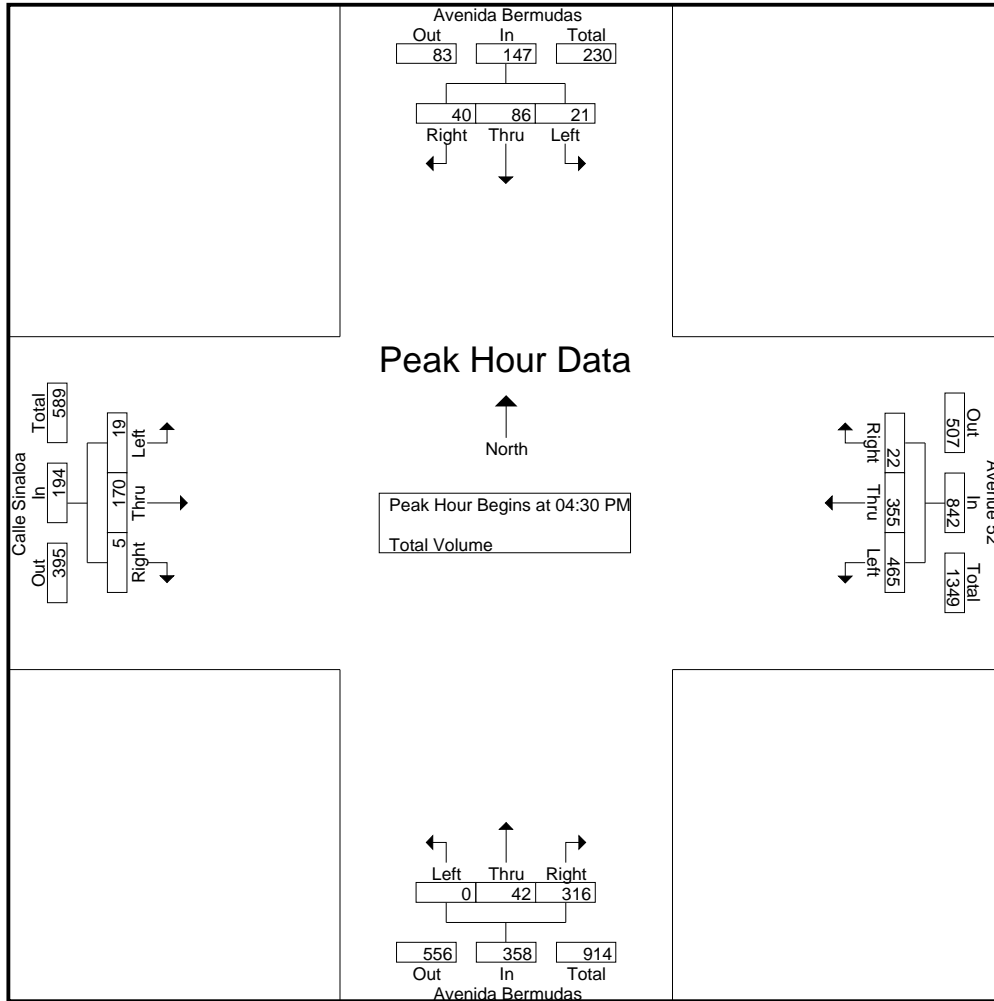

Peak Hour Analysis From 02:30 PM to 05:15 PM - Peak 1 of 1

Peak Hour for Each Approach Begins at:

	04:15 PM				04:15 PM				04:30 PM				04:30 PM			
+0 mins.	7	15	8	30	133	94	8	235	0	10	92	102	6	47	0	53
+15 mins.	10	23	9	42	140	70	3	213	0	10	78	88	5	36	2	43
+30 mins.	3	22	9	34	104	102	4	210	0	12	69	81	4	33	1	38
+45 mins.	6	24	12	42	110	80	8	198	0	10	77	87	4	54	2	60
Total Volume	26	84	38	148	487	346	23	856	0	42	316	358	19	170	5	194
% App. Total	17.6	56.8	25.7		56.9	40.4	2.7		0	11.7	88.3		9.8	87.6	2.6	
PHF	.650	.875	.792	.881	.870	.848	.719	.911	.000	.875	.859	.877	.792	.787	.625	.808

City of La Quinta
 N/S: Washington Street
 E/W: Eisenhower Drive
 Weather: Sunny

File Name : LQAWAEIPM
 Site Code : 10122159
 Start Date : 5/25/2010
 Page No : 1

Groups Printed- Total Volume

Start Time	Washington Street Southbound				Eisenhower Drive Westbound				Washington Street Northbound				Eisenhower Drive Eastbound				Int. Total
	Left	Thru	Right	App. Total	Left	Thru	Right	App. Total	Left	Thru	Right	App. Total	Left	Thru	Right	App. Total	
02:30 PM	2	182	10	194	35	24	4	63	38	178	10	226	12	20	50	82	565
02:45 PM	6	158	17	181	21	18	5	44	39	251	28	318	28	23	68	119	662
Total	8	340	27	375	56	42	9	107	77	429	38	544	40	43	118	201	1227
03:00 PM	2	141	25	168	21	14	2	37	43	217	20	280	20	19	45	84	569
03:15 PM	7	166	7	180	15	19	4	38	52	242	21	315	25	8	44	77	610
03:30 PM	4	157	13	174	28	17	5	50	68	268	26	362	25	17	37	79	665
03:45 PM	3	158	17	178	6	6	3	15	39	241	20	300	30	17	27	74	567
Total	16	622	62	700	70	56	14	140	202	968	87	1257	100	61	153	314	2411
04:00 PM	5	138	11	154	17	22	3	42	33	245	21	299	25	15	31	71	566
04:15 PM	3	173	18	194	11	10	5	26	29	229	13	271	17	16	31	64	555
04:30 PM	1	191	17	209	13	19	1	33	51	227	13	291	16	15	18	49	582
04:45 PM	4	164	13	181	16	14	3	33	51	271	20	342	24	18	30	72	628
Total	13	666	59	738	57	65	12	134	164	972	67	1203	82	64	110	256	2331
05:00 PM	2	167	13	182	23	19	1	43	41	255	28	324	9	15	34	58	607
05:15 PM	3	175	21	199	15	13	3	31	49	322	21	392	24	15	28	67	689
Grand Total	42	1970	182	2194	221	195	39	455	533	2946	241	3720	255	198	443	896	7265
Apprch %	1.9	89.8	8.3		48.6	42.9	8.6		14.3	79.2	6.5		28.5	22.1	49.4		
Total %	0.6	27.1	2.5	30.2	3	2.7	0.5	6.3	7.3	40.6	3.3	51.2	3.5	2.7	6.1	12.3	

Start Time	Washington Street Southbound				Eisenhower Drive Westbound				Washington Street Northbound				Eisenhower Drive Eastbound				Int. Total
	Left	Thru	Right	App. Total	Left	Thru	Right	App. Total	Left	Thru	Right	App. Total	Left	Thru	Right	App. Total	
Peak Hour Analysis From 02:30 PM to 04:45 PM - Peak 1 of 1																	
Peak Hour for Entire Intersection Begins at 02:45 PM																	
02:45 PM	6	158	17	181	21	18	5	44	39	251	28	318	28	23	68	119	662
03:00 PM	2	141	25	168	21	14	2	37	43	217	20	280	20	19	45	84	569
03:15 PM	7	166	7	180	15	19	4	38	52	242	21	315	25	8	44	77	610
03:30 PM	4	157	13	174	28	17	5	50	68	268	26	362	25	17	37	79	665
Total Volume	19	622	62	703	85	68	16	169	202	978	95	1275	98	67	194	359	2506
% App. Total	2.7	88.5	8.8		50.3	40.2	9.5		15.8	76.7	7.5		27.3	18.7	54		
PHF	.679	.937	.620	.971	.759	.895	.800	.845	.743	.912	.848	.881	.875	.728	.713	.754	.942

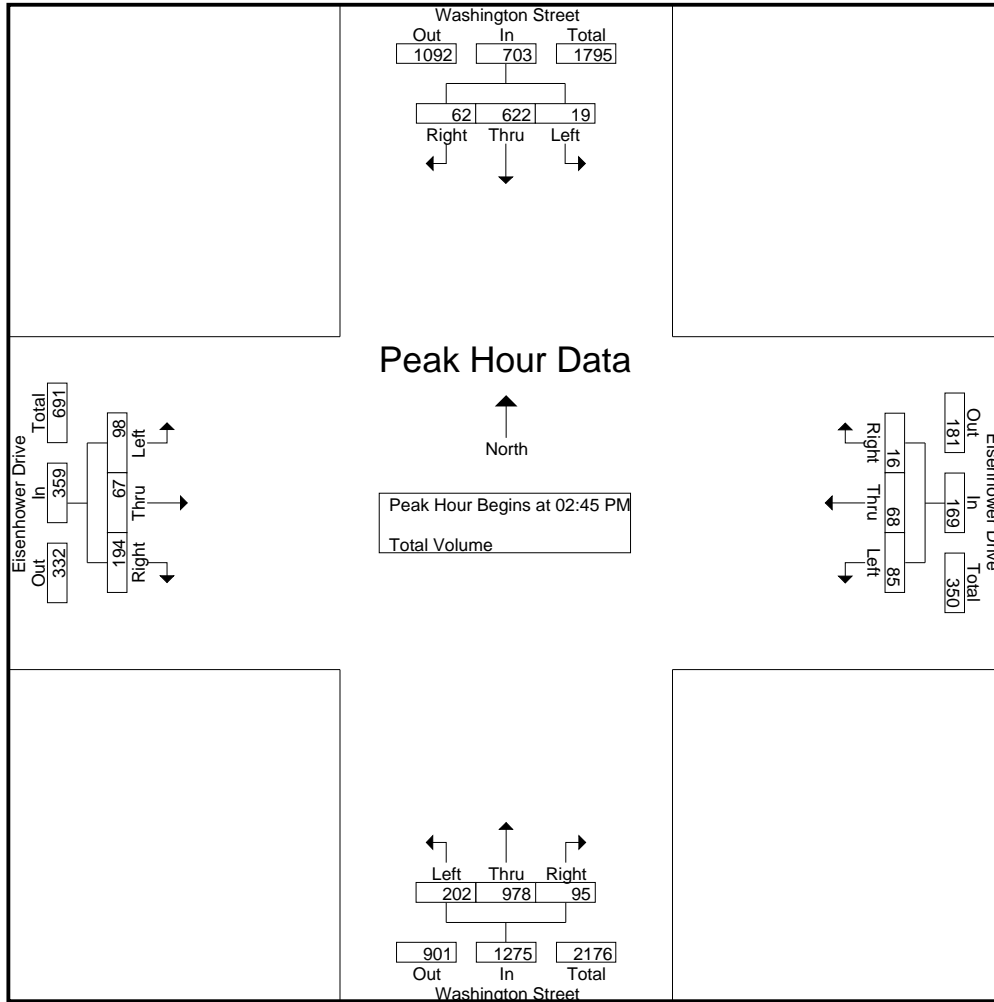

Peak Hour Analysis From 02:30 PM to 04:45 PM - Peak 1 of 1
 Peak Hour for Each Approach Begins at:

	04:00 PM				02:30 PM				03:15 PM				02:30 PM			
+0 mins.	5	138	11	154	35	24	4	63	52	242	21	315	12	20	50	82
+15 mins.	3	173	18	194	21	18	5	44	68	268	26	362	28	23	68	119
+30 mins.	1	191	17	209	21	14	2	37	39	241	20	300	20	19	45	84
+45 mins.	4	164	13	181	15	19	4	38	33	245	21	299	25	8	44	77
Total Volume	13	666	59	738	92	75	15	182	192	996	88	1276	85	70	207	362
% App. Total	1.8	90.2	8		50.5	41.2	8.2		15	78.1	6.9		23.5	19.3	57.2	
PHF	.650	.872	.819	.883	.657	.781	.750	.722	.706	.929	.846	.881	.759	.761	.761	.761

City of La Quinta
 N/S: Washington Street
 E/W: Calle Tampico
 Weather: Sunny

File Name : LQAWACTPM
 Site Code : 10122099
 Start Date : 5/25/2010
 Page No : 1

Groups Printed- Total Volume

Start Time	Washington Street Southbound				Calle Tampico Westbound				Washington Street Northbound				Calle Tampico Eastbound				Int. Total
	Left	Thru	Right	App. Total	Left	Thru	Right	App. Total	Left	Thru	Right	App. Total	Left	Thru	Right	App. Total	
02:30 PM	10	98	44	152	7	10	8	25	9	80	6	95	50	16	12	78	350
02:45 PM	8	149	62	219	8	11	8	27	12	102	6	120	66	11	15	92	458
Total	18	247	106	371	15	21	16	52	21	182	12	215	116	27	27	170	808
03:00 PM	10	134	71	215	7	15	6	28	7	84	6	97	53	16	7	76	416
03:15 PM	12	136	79	227	4	6	9	19	13	99	8	120	60	15	5	80	446
03:30 PM	10	118	64	192	8	9	7	24	12	86	0	98	68	12	8	88	402
03:45 PM	13	153	73	239	12	18	6	36	19	80	8	107	67	23	9	99	481
Total	45	541	287	873	31	48	28	107	51	349	22	422	248	66	29	343	1745
04:00 PM	13	121	74	208	7	13	3	23	7	61	3	71	72	14	7	93	395
04:15 PM	5	142	69	216	4	13	3	20	11	73	9	93	63	19	8	90	419
04:30 PM	9	126	71	206	5	13	5	23	14	98	5	117	65	13	10	88	434
04:45 PM	18	167	80	265	6	7	8	21	5	81	9	95	50	17	11	78	459
Total	45	556	294	895	22	46	19	87	37	313	26	376	250	63	36	349	1707
05:00 PM	7	157	75	239	3	11	5	19	7	94	6	107	70	21	8	99	464
05:15 PM	13	181	98	292	6	7	9	22	13	96	2	111	71	18	6	95	520
Grand Total	128	1682	860	2670	77	133	77	287	129	1034	68	1231	755	195	106	1056	5244
Apprch %	4.8	63	32.2		26.8	46.3	26.8		10.5	84	5.5		71.5	18.5	10		
Total %	2.4	32.1	16.4	50.9	1.5	2.5	1.5	5.5	2.5	19.7	1.3	23.5	14.4	3.7	2	20.1	

Start Time	Washington Street Southbound				Calle Tampico Westbound				Washington Street Northbound				Calle Tampico Eastbound				Int. Total
	Left	Thru	Right	App. Total	Left	Thru	Right	App. Total	Left	Thru	Right	App. Total	Left	Thru	Right	App. Total	
04:30 PM	9	126	71	206	5	13	5	23	14	98	5	117	65	13	10	88	434
04:45 PM	18	167	80	265	6	7	8	21	5	81	9	95	50	17	11	78	459
05:00 PM	7	157	75	239	3	11	5	19	7	94	6	107	70	21	8	99	464
05:15 PM	13	181	98	292	6	7	9	22	13	96	2	111	71	18	6	95	520
Total Volume	47	631	324	1002	20	38	27	85	39	369	22	430	256	69	35	360	1877
% App. Total	4.7	63	32.3		23.5	44.7	31.8		9.1	85.8	5.1		71.1	19.2	9.7		
PHF	.653	.872	.827	.858	.833	.731	.750	.924	.696	.941	.611	.919	.901	.821	.795	.909	.902

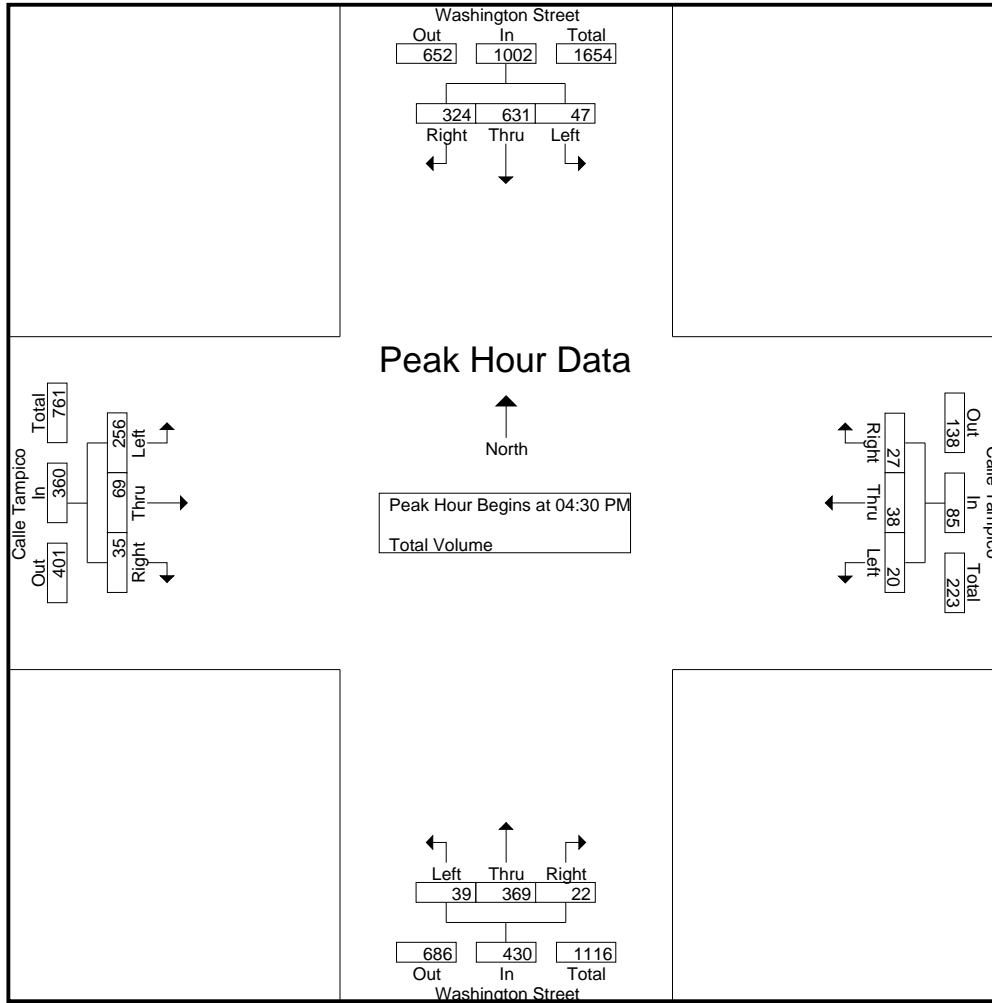

Peak Hour Analysis From 02:30 PM to 05:15 PM - Peak 1 of 1

Peak Hour for Each Approach Begins at:

	04:30 PM				03:00 PM				02:45 PM				03:30 PM			
+0 mins.	9	126	71	206	7	15	6	28	12	102	6	120	68	12	8	88
+15 mins.	18	167	80	265	4	6	9	19	7	84	6	97	67	23	9	99
+30 mins.	7	157	75	239	8	9	7	24	13	99	8	120	72	14	7	93
+45 mins.	13	181	98	292	12	18	6	36	12	86	0	98	63	19	8	90
Total Volume	47	631	324	1002	31	48	28	107	44	371	20	435	270	68	32	370
% App. Total	4.7	63	32.3		29	44.9	26.2		10.1	85.3	4.6		73	18.4	8.6	
PHF	.653	.872	.827	.858	.646	.667	.778	.743	.846	.909	.625	.906	.938	.739	.889	.934

City of La Quinta
 N/S: Washington Street
 E/W: 52nd Avenue
 Weather: Sunny

File Name : LQAWA52PM
 Site Code : 10122139
 Start Date : 5/25/2010
 Page No : 1

Groups Printed- Total Volume

Start Time	Washington Street Southbound				52nd Avenue Westbound				Washington Street Northbound				52nd Avenue Eastbound				Int. Total
	Left	Thru	Right	App. Total	Left	Thru	Right	App. Total	Left	Thru	Right	App. Total	Left	Thru	Right	App. Total	
02:30 PM	60	1	78	139	2	51	37	90	2	8	5	15	69	49	1	119	363
02:45 PM	57	1	113	171	0	62	40	102	1	3	1	5	71	71	1	143	421
Total	117	2	191	310	2	113	77	192	3	11	6	20	140	120	2	262	784
03:00 PM	49	6	91	146	0	74	38	112	1	1	5	7	61	64	1	126	391
03:15 PM	49	4	85	138	2	76	42	120	0	4	2	6	68	42	0	110	374
03:30 PM	36	3	82	121	5	82	34	121	1	8	3	12	52	55	1	108	362
03:45 PM	56	5	101	162	2	59	38	99	0	5	1	6	58	57	2	117	384
Total	190	18	359	567	9	291	152	452	2	18	11	31	239	218	4	461	1511
04:00 PM	43	4	88	135	2	75	37	114	5	4	1	10	37	46	2	85	344
04:15 PM	44	3	115	162	0	89	41	130	0	1	1	2	66	48	2	116	410
04:30 PM	45	1	78	124	1	72	33	106	0	1	4	5	75	68	3	146	381
04:45 PM	46	2	118	166	1	73	30	104	0	2	1	3	60	33	0	93	366
Total	178	10	399	587	4	309	141	454	5	8	7	20	238	195	7	440	1501
05:00 PM	46	5	104	155	1	69	36	106	0	5	1	6	56	59	1	116	383
05:15 PM	49	7	131	187	1	85	36	122	0	5	3	8	61	61	0	122	439
Grand Total	580	42	1184	1806	17	867	442	1326	10	47	28	85	734	653	14	1401	4618
Apprch %	32.1	2.3	65.6		1.3	65.4	33.3		11.8	55.3	32.9		52.4	46.6	1		
Total %	12.6	0.9	25.6	39.1	0.4	18.8	9.6	28.7	0.2	1	0.6	1.8	15.9	14.1	0.3	30.3	

Start Time	Washington Street Southbound				52nd Avenue Westbound				Washington Street Northbound				52nd Avenue Eastbound				Int. Total
	Left	Thru	Right	App. Total	Left	Thru	Right	App. Total	Left	Thru	Right	App. Total	Left	Thru	Right	App. Total	
Peak Hour Analysis From 02:30 PM to 05:15 PM - Peak 1 of 1																	
Peak Hour for Entire Intersection Begins at 04:30 PM																	
04:30 PM	45	1	78	124	1	72	33	106	0	1	4	5	75	68	3	146	381
04:45 PM	46	2	118	166	1	73	30	104	0	2	1	3	60	33	0	93	366
05:00 PM	46	5	104	155	1	69	36	106	0	5	1	6	56	59	1	116	383
05:15 PM	49	7	131	187	1	85	36	122	0	5	3	8	61	61	0	122	439
Total Volume	186	15	431	632	4	299	135	438	0	13	9	22	252	221	4	477	1569
% App. Total	29.4	2.4	68.2		0.9	68.3	30.8		0	59.1	40.9		52.8	46.3	0.8		
PHF	.949	.536	.823	.845	1.000	.879	.938	.898	.000	.650	.563	.688	.840	.813	.333	.817	.894

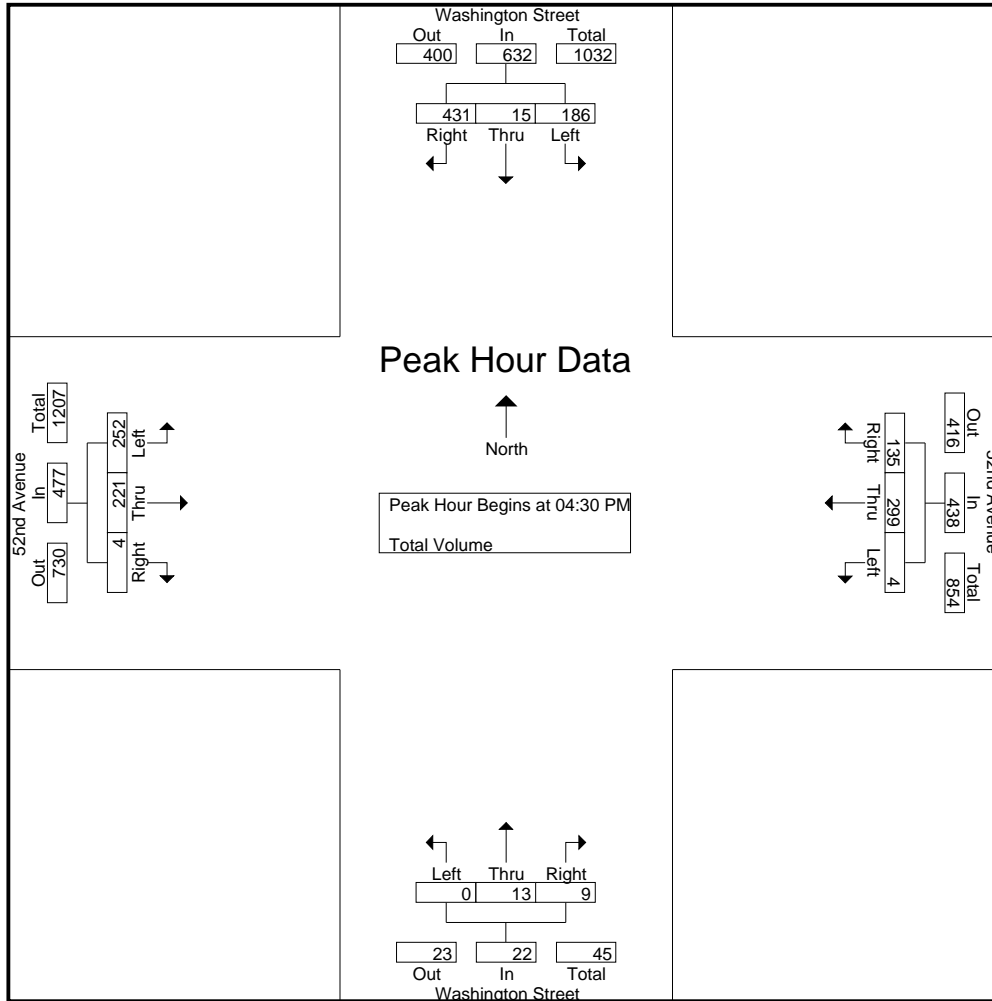

Peak Hour Analysis From 02:30 PM to 05:15 PM - Peak 1 of 1

Peak Hour for Each Approach Begins at:

	04:30 PM				03:30 PM				03:15 PM				02:30 PM			
+0 mins.	45	1	78	124	5	82	34	121	0	4	2	6	69	49	1	119
+15 mins.	46	2	118	166	2	59	38	99	1	8	3	12	71	71	1	143
+30 mins.	46	5	104	155	2	75	37	114	0	5	1	6	61	64	1	126
+45 mins.	49	7	131	187	0	89	41	130	5	4	1	10	68	42	0	110
Total Volume	186	15	431	632	9	305	150	464	6	21	7	34	269	226	3	498
% App. Total	29.4	2.4	68.2		1.9	65.7	32.3		17.6	61.8	20.6		54	45.4	0.6	
PHF	.949	.536	.823	.845	.450	.857	.915	.892	.300	.656	.583	.708	.947	.796	.750	.871

This Page Intentionally Left Blank